

**Sample Paper – 2014**  
**Class – X**  
**Subject – Mathematics**

Time: 3 hours

Maximum marks: 90

General Instructions:

1. All questions are **compulsory**.
2. The question paper consists of 34 questions divided into 4 sections, A, B, C, D **Section-A** comprises of 8 questions of **1 mark** each. **Section-B** comprises of 6 questions of **2 marks** each. **Section-C** comprises of 10 questions of **3 marks** each and **Section D**; comprises of 10 questions of **4 marks** each.
3. Question numbers 1 to 8 in Sections-A are multiple choice questions where you select one correct option out of the given four.
4. There is no overall choice. However, internal choice has been provided in 1 question two marks, 3 questions of three marks each and 2 questions of four marks each have to attempt only one of the alternatives in all such questions.
5. Use of calculators is not permitted.

**Section A**

1. If the equation  $x^2 + 4x + k = 0$  has real and distinct roots, then  
(a)  $K < 4$  (b)  $k > 4$  (c)  $k \geq 4$  (d)  $k \leq 4$
2. If  $x > y > 0$ ,  $x^2 + y^2 = 13$  and  $xy = 6$ , then  $y =$   
(a) 4 (b) 3 (c) 2 (d) None of these
3. If the area of the triangle formed by the points  $(k, 4/3)$ ,  $(-2, 6)$  and  $(3, 1)$  is 5 sq units, then  $k$  is  
(a) 3 (b) 5 (c)  $2/3$  (d)  $3/5$
4. The sum of  $n$  term of an AP is  $3n^2 + 5n$ , then 164 is its  
(a) 24<sup>th</sup> term (b) 27<sup>th</sup> term (c) 29<sup>th</sup> term (d) None of these
5. If first term of an AP is  $a$  and  $n^{\text{th}}$  term is  $b$ , then its common difference is  
(a)  $(b-a)/n+1$  (b)  $(b-a)/n-1$  (c)  $(b-a)/n$  (d) None of these
6. The height of a tower is  $100\sqrt{3}$  m. the angle of elevation of its top from a point 100 m away from its foot is  
(a)  $30^\circ$  (b)  $45^\circ$  (c)  $60^\circ$  (d) None of these

7. Which was the first book on Probability?
  - (a) Dealing with possibilities
  - (b) World of chances
  - (c) Book on games of chance
  - (d) None of the above
  
8. A letter is chosen at random from the letters of the word 'Apple'. Find the probability that the letter chosen is a consonant.
  - (a)  $\frac{1}{5}$
  - (b)  $\frac{2}{5}$
  - (c)  $\frac{3}{5}$
  - (d) None of these

### Section B

9. Find the value of K so that the sum of the roots of the equation  $3x^2 + (2k+1)x - k - 5 = 0$  is equal to the product of roots.
10. Show that the roots of the equation.  $(x - a)(x - b) + (x - b)(x - c) + (x - c)(x - a) = 0$  are always real and they cannot be equal unless  $a = b = c$ .
11. Solve for x,  $4\sqrt{6}x^2 - 13x - 2\sqrt{6} = 0$  by using a completing the square.
12. Prove that the tangents drawn at the ends of a diameter of a circle are parallel.
13. Find the distance between the points P (-4, 0) and Q (2,-5).
14. Divide a line segment of length 8 cm internally in the ratio 4: 5. Also, give justification of the construction.

### Section C

15. Find the centre of a circle passing through the points (6, -6), (3, -7) and (3, 3). Also find the radius.
  
16. One natural number is 3 times the other number. Sum of their squares exceeds 13 times of the greatest number by 4. Find both the numbers.
  
17. What is the probability that a leap year, selected at random will contain 53 Sundays?
  
18. Find the 103<sup>th</sup> term of the AP 4,  $4\frac{1}{2}$ , 5,  $5\frac{1}{2}$ , 6 .....
  
19. Prove that  $t_{m+n} + t_{m-n} = 2t_m$ , where  $t_m$  is an nth term.
  
20. For what value of n, the nth term of the following two A.P.'s are equal?
  
21. 20, 25, 30, 35... And -17, -10, -3, 4...
  
22. Two concentric circles are of radii 5 cm and 3 cm. Find the length of the chord of the larger circle which touches the smaller circle

23. Prove that opposite sides of a quadrilateral circumscribing a circle subtend supplementary angles at the centre of the circle.

24. A copper wire 0.4 cm in diameter is evenly wound about a cylinder whose length is 24 cm and diameter 20 cm so as to cover the whole surface. Find the length and weight of the wire assuming the specific gravity to be  $10 \text{ gm/cm}^3$ .

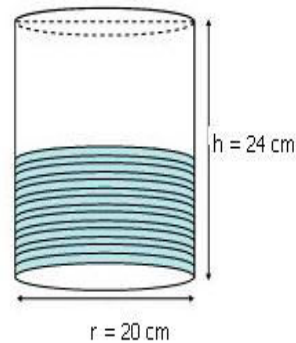

25. 500 men took a dip in an 80 m long and 50 m broad tank for rain water harvesting. What is the rise in the water level if the average displacement of water by a man is 4 sq m? What value is shown by the men?

### Section D

26. If the sides of a right angled triangle are  $x$ ,  $x + 1$  and  $x - 1$ , find the hypotenuse.

27. Find the ratio in which the line  $2x + y - 4 = 0$  divides the line segment joining A (2, -2) and B (3, 7).

28. A metallic cylinder has radius 3 mm and height 5 mm. It is made of a metal A. to reduce its weight, a conical hole is drilled in the cylinder as shown in the figure and it completely filled with a lighter metal B. the conical hole has a radius of 1.5 mm and its depth is  $\frac{8}{9}$  mm. calculate the ratio of the volume of the metal A to the volume of metal B in the solid.

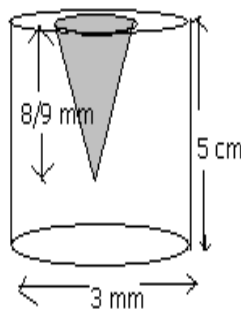

29. The adjoining figure shows the cross section of an ice cream consisting of a cone surmounted by a hemisphere. The radius of the hemisphere is 3.5 cm and the height of the cone is 10.5 cm. The outer shell ABCDFE is shaded and it is not filled with ice cream.  $AE = DC = 0.5$  cm, and  $AB$  is parallel to  $EF$ ,  $BC$  is parallel to  $FD$

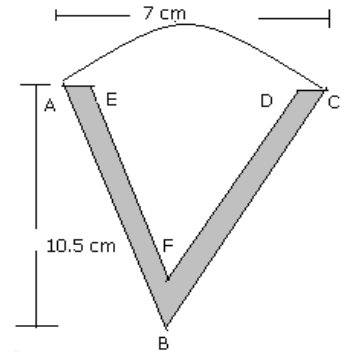

- Calculate:
- The volume of the ice cream in the cone (the unshaded portion including the hemisphere)
  - The volume of the outer shell (the shaded portion)
30. Two circles touch externally. The sum of their areas is  $130\pi$  sq cm and the distance between the centers is 14 cm. Find the radii of the circles.
31. In the given figure, a crescent is formed by two circles which touch at A. C is the centre of the larger circle. The width of the crescent at  $BD = 9$  cm and at  $EF$  it is 5 cm. Find the radii of two circles and the area of the shaded region.

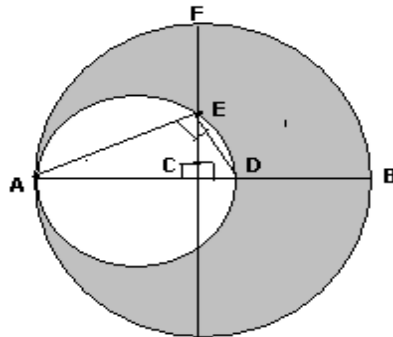

32. Two pillars of equal heights stand on either side of a road which is 150m wide. At a point on the road between the pillars, the angles of elevation of the tops of the pillars are  $60^\circ$  and  $30^\circ$ . Find the height of each pillar and the position of the point on the road.
33. Construct a triangle of sides 4 cm, 5cm and 6cm and then a triangle similar to it whose sides are  $\frac{2}{3}$  of the corresponding sides of the first triangle. Give the justification of the construction.
34. A bag contains only black and white balls. The probability of picking at random a black ball from the bag is  $\frac{7}{10}$ .
- What is the probability of picking a white ball from the bag?
  - Can you say how many black and white balls are in the bag?



<http://www.cbseguess.com/>

Hemant K. Sharma  
Delhi Public School  
Mathura Refinery Nagar, Mathura  
E-Mail Id: [hkumarsharma@gmail.com](mailto:hkumarsharma@gmail.com)

[www.cbseguess.com](http://www.cbseguess.com)

Other Educational Portals

[www.icseguess.com](http://www.icseguess.com) | [www.ignouguess.com](http://www.ignouguess.com) | [www.aipmtguess.com](http://www.aipmtguess.com) | [www.aieeeguess.com](http://www.aieeeguess.com) |  
[www.niosguess.com](http://www.niosguess.com) | [www.iitguess.com](http://www.iitguess.com)