

Sample Paper – 2014
Class – XII
Subject – COMPUTER SCIENCE

Instructions:

- i) All questions are compulsory.
- ii) Programming Language : C++

1. a) What are static data members and illustrate their properties? 2
- b) Name the header files that will be needed for the following code: 2
- ```
void main()
{
 char *p;
 float s;
 gets(p);
 s = atof(p);
 cout<<p<<setprecision(2)<<s;
}
```
- c) Give the output of the following code. 3
- ```
#include<iostream.h>
int a=10;
void main()
{
    void demo(int &,int,int*);
    int a=20,b=5;
    demo(::a,a,&b);
    cout<<::a<<'\t'<<a<<'\t'<<b<<endl;
}
void demo(int &x, int y, int *z)
{
    a+=x;
    y*=a;
    *z=a+y;
    cout<<x<<y<<*z<<endl;
}
```
- d) Find the output of the following program: 1
- ```
#include<iostream.h>
#include<ctype.h>

void main ()
{
 char Text [] = "Mind@Work!";
 for (int I = 0; Text [I] != '\0'; I++)
 {
 if (!isalpha (Text[I]))
 Text [I] = '*';
 else if (isupper (Text[I]))
 Text [I] = Text [I] + 1 ;
 else
 Text [I] = Text [I+ 1];
 }
 cout<<Text;
}
```

e) Give the output of the following program. 3

```
#include<iostream.h>
void sumfn(int last)
{
 auto int sum = 0;
 static int sum2 = 0;
 for(int i = last; i > 0; i--)
 sum += i;
 sum2 += sum;
 cout<<sum<<" "<<sum2<<endl;
}
void main()
{
 for(int i = 1; i < 7; i++)
 sumfn(i);
}
```

2. a. Differentiate between public and private visibility modes in context of Object Oriented Programming using a suitable example illustrating each. 2

b. Define a class **Garments** in C++ with the following descriptions: 4

Private Members:

GCode of type string

GType of type string

GSize of type integer

GFabric of type string

GPrice of type float

A function Assign ( ) which calculates and assigns the value of GPrice as follows

For the value of GFabric as "COTTON",

| GType   | GPrice(Rs) |
|---------|------------|
| TROUSER | 1300       |
| SHIRT   | 1100       |

For GFabric other than "COTTON" the above mentioned

GPrice gets reduced by 10%.

Public Members:

- A constructor to assign initial values of GCode, GType and GFabric with the word "NOT ALLOTTED" and GSize and GPrice with 0

- A function Input ( ) to input the values of the data members GCode, GType, GSize and GFabric and invoke the Assign ( ) function.

- A function Display ( ) which displays the content of all the data members for a Garment.

c. Answer the questions (i) to (iv) based on the following: 4

```
class PUBLISHER
{
 char Pub[12];
 double Turnover;
protected:
 void Register();
public:
 PUBLISHER();
 void Enter();
 void Display();
};
class BRANCH
{
 char CITY[20];
protected:
```

```
float Employees;
public:
BRANCH();
void Haveit();
void Giveit();
};
class AUTHOR : private BRANCH , public PUBLISHER
{
int Acode;
char Aname[20];
float Amount;
public:
AUTHOR();
void Start();
void Show();
};
```

- (i) Write the names of data members, which are accessible from objects belonging to class AUTHOR.
- (ii) Write the names of all the member functions which are accessible from objects belonging to class BRANCH.
- (iii) Write the names of all the members which are accessible from member functions of class AUTHOR.
- (iv) How many bytes will be required by an object belonging to class AUTHOR?

- 3 a. Write a program that display the size of a file in bytes. 2
- b. Observe the program segment given below carefully, and answer the question that follows: 1

```
class Applicant
{
long AId; //Applicant's Id
char Name [20] ; //Applicant's Name
float Score; //Applicant's Score
public:
void Enroll ();
void Disp () ;
void MarksScore () ; //Function to change Score
long R_AId () {returnAId;}
};
void ScoreUpdate (long Id)
{
fstream File;
File.open ("APPLI.DAT",ios::binary|ios::in|ios::out);
Applicant A;
int Record = 0, Found = 0 ;
while (!Found && File.read((char*) &C, sizeof(c)))
{
if(Id ==A.R_AId ())
{
cout<<"Enter new Score" ;
A.MarksScore ();
_____ // Statement 1
_____ //Statement 2
}
Found = 1;
}
Record ++;
}
```

```
if (Found ==1) cout<<"Record Updated";
File.close () ;
}
```

Write the Statement1 **to position** the File Pointer at the beginning of the Record for which the Applicant's Id matches with the argument passed, and Statement2 **to write** the updated Record at that position.

- c. Given a binary file PHONE.DAT, containing records of the following structure type 3

```
class Phonlist
{
char Name [20] ;
char Address[30];
char AreaCode[5];
char PhoneNo[15] ;
public:
void Register () ;
Void Show () ;
int CheckCode (char AC [])
{
return strcmp (AreaCode, AC) ;
}
};
```

Write a function TRANSFER ( ) in C++, that would copy all those records which are having AreaCode as "DEL" from PHONE.DAT to PHONBACK.DAT.

- 4 a. Given two arrays of integers A and B of sizes M and N respectively. Write a function named MIX() which will produce a third array named C, such that the following sequence is followed :  
 All even numbers of A from left to right are copied into C from left to right.  
 All odd numbers of A from left to right are copied into C from right to left  
 All even numbers of B from left to right are copied into C from left to right.  
 All odd numbers of B from left to right are copied into C from right to left  
 A, B and C are passed as arguments to MIX(). 4

- b. Suppose an array P containing float is arranged in ascending order. Write a user defined function in C++ to search for one float from P with the help of binary search method. The function should return an integer 0 to show absence of the number and integer 1 to show presence of the number in the array. The function should have the parameters as (1) an array (2) the number DATA to be searched (3) number of element N. 3

- c. Write a function which accepts a 2D array of integers, number of rows and number of columns as arguments and assign the elements which are divisible by 3 or 5 into a one dimensional array of integers. 3  
 If the 2D array is

|    |    |    |    |
|----|----|----|----|
| 11 | 5  | 28 | 18 |
| 19 | 32 | 45 | 27 |
| 24 | 25 | 16 | 31 |
| 12 | 3  | 9  | 14 |

The resultant 1D arrays is 12 , 3 , 9 , 24 , 25 , 45 , 9 , 5 , 18

- d. An array X[20][20] is stored in the memory with each element requiring 4 bytes of storage. If the address of X[10][12] is 2596, find out the memory location X[12][14] for row major arrangement. 3
- e. Convert ((A + B) – ((C + D) \* E / F) \* G) into postfix form showing stack status after every step in tabular form. 3
- f. Each node of a STACK containing the following information, in addition to required pointer field: 3

Roll no. of the student  
 Age of the student.  
 Give the structure of node for the linked stack in question.

TOP is a pointer to the topmost node of the STACK. Write the following function:

PUSH ( ) – TO push a node in to the stack which is allocated dynamically.  
 POP ( ) – To remove a node from the stack and to release the memory.

- 5 a. What are the different constraints that can be applied on the table? 2
- b. Write SQL commands for i) to iv) and the outputs for v) on the basis of tables FURNITURE and ARRIVALS. 6

TABLE FURNITURE

| NO | ITEMNAME        | TYPE         | DATEOFSTOCK | PRICE | DISCOUNT |
|----|-----------------|--------------|-------------|-------|----------|
| 1  | White lotus     | Double Bed   | 23-02-09    | 30000 | 25       |
| 2  | Pink feather    | Baby cot     | 20-01-09    | 7000  | 20       |
| 3  | Dolphin         | Baby cot     | 19-02-09    | 9500  | 20       |
| 4  | Decent          | Office Table | 01-01-09    | 25000 | 30       |
| 5  | Comfort zone    | Double Bed   | 12-01-09    | 25000 | 25       |
| 6  | Donald          | Baby cot     | 24-02-09    | 6500  | 15       |
| 7  | Royal Finish    | Office Table | 20-02-09    | 18000 | 30       |
| 8  | Royal tiger     | Sofa         | 22-02-09    | 31000 | 30       |
| 9  | Econo sitting   | Sofa         | 13-12-08    | 9500  | 25       |
| 10 | Eating Paradise | Dining Table | 19-02-09    | 11500 | 25       |

TABLE ARRIVALS

| NO | ITEMNAME     | TYPE       | DATEOFSTOCK | PRICE | DISCOUNT |
|----|--------------|------------|-------------|-------|----------|
| 11 | Wood Comfort | Double Bed | 23-03-10    | 2500  | 25       |
| 12 | Old fox      | Sofa       | 20-02-10    | 17000 | 20       |
| 13 | Micky        | Baby cot   | 21-02-10    | 7500  | 15       |

- i) To list the items those are priced at more than 15000 from FURNITURE table.
- ii) To list the items and their type which were stocked before 22/01/08 in the descending order of items.
- iii) To display items and their dateof stock where the discount percentage is more than 25.
- iv) To count the number of items whose type is “Sofa”.
- v) Give the outputs for the following statements.
1. SELECT COUNT (DISTINCT TYPE) FORM FURNITURE;
  2. SELECT MAX(DISCOUNT) FROM FURNITURE , ARRIVALS;
  3. SELECT AVG(DISOCUNT) FROM FURNITURE WHERE TYPE = “Baby cot”;
  4. SELECT SUM(PRICE) FROM FURNITURE WHERE DATOFSTOCK < ‘12/02/09’;
- 6 a. State and verify Demorgan's Laws algebraically. 2
- b. Write the equivalent Boolean Expression for the following Logic Circuit 2

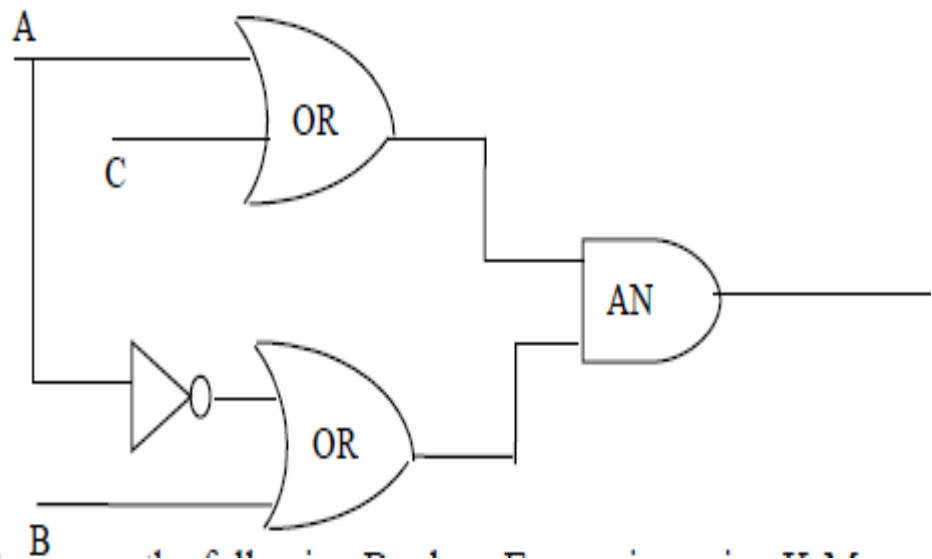

c. Write the POS form of a Boolean function F, which is represented in a truth table as follows: 1

| U | V | W | F |
|---|---|---|---|
| 0 | 0 | 0 | 1 |
| 0 | 0 | 1 | 0 |
| 0 | 1 | 0 | 1 |
| 0 | 1 | 1 | 0 |
| 1 | 0 | 0 | 1 |
| 1 | 0 | 1 | 0 |
| 1 | 1 | 0 | 1 |
| 1 | 1 | 1 | 1 |

d. Reduce the following Boolean Expression using K-Map: 3  
 $F(A,B,C,D) = \sum (0,1,2,4,5,6,8,10)$

7 a. Compare any two Switching techniques. 1

b. Which of the following is not a Client Side script: 1  
 (i) VB Script (ii) Java Script  
 (iii) ASP (iv) PHP

c. If someone has hacked your Website, to whom you lodge the Complain? 1

d. What do you mean by IP Address? How is it useful in Computer Security? 1

e. Knowledge Supplement Organisation has set up its new center at Mangalore for its office and web based activities. It has 4 blocks of buildings as shown in the diagram below: 4

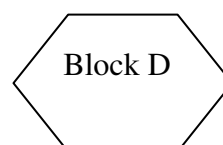
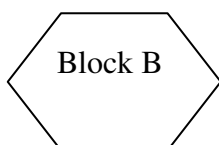
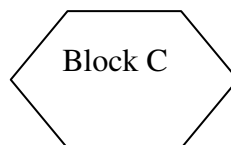
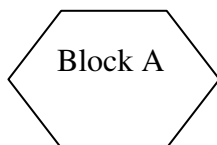

**Center to center distances between various blocks**

|                    |       |
|--------------------|-------|
| Block A to Block B | 50 m  |
| Block B to Block C | 150 m |
| Block C to Block D | 25 m  |
| Block A to Block D | 170 m |
| Block B to Block D | 125 m |
| Block A to Block C | 90 m  |

**Number of Computers**

|         |     |
|---------|-----|
| Block A | 25  |
| Block B | 50  |
| Block C | 125 |
| Block D | 10  |

- 1) Suggest a cable layout of connections between the blocks.
- 2) Suggest the most suitable place (i.e. block) to house the server of this organisation with a suitable reason.
- 3) Suggest the placement of the following devices with justification
  - (i) Repeater
  - (ii) Hub/Switch
- 4) The organization is planning to link its front office situated in the city in a hilly region where cable connection is not feasible, suggest an economic way to connect it with reasonably high speed?
- f. What do you mean by Spam Mails? How can you protect your mailbox from Spams? 1
- g. Mention any two advantages of Open Source Software over Proprietary Software.

1

**Paper Submitted by:**

Name           Girija Nagarajan  
 Email           girija.nagarajan@gmail.com  
 Phone No.   9900213145