

CLASS XII GUESS PAPER PHYSICS

SECTION - A

1. Explain the orientation of an electric dipole in a uniform electric field corresponds to its stable equilibrium .
2. A conductor carrying current placed somewhere . What is the magnitude and direction of the field due to a small part of the conductor at a point near it ?
3. Find the virtual vale of current through a capacitor of capacitance $10\mu\text{F}$, when connected to a source of 110Volt at 50 cycles supply.
4. The shown in the figure is made of two different materials . A point object is placed on the axis . How many images of the object will it form ?

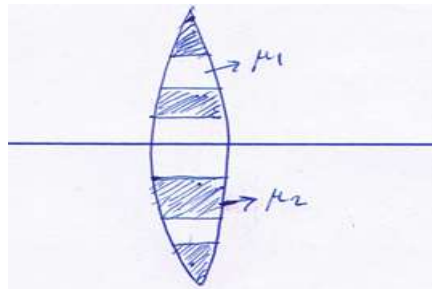

5. Draw the output wave form across the diode in the circuit shown in fig.

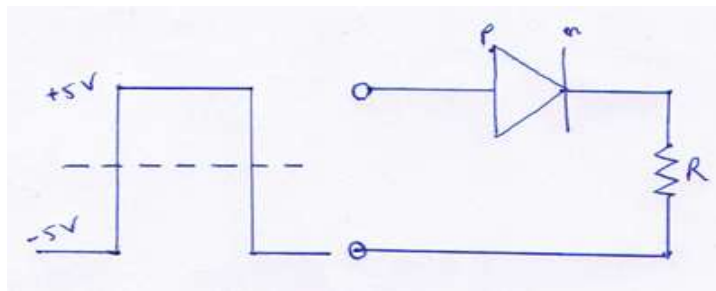

SECTION – B

6. Answer the following questions :

a) A steady current flows in a metallic conductor of non-uniform cross-section . Which of these quantities is constant along the conductor : current , current density , drift speed ?

b) Is Ohm's law universally applicable for all conducting materials ? If not , give examples of the materials which do not obey the Ohm's law .

7. In an experimental arrangement of two coils C_1 and C_2 placed coaxially parallel to each other , find out the expression for the emf induced in the coil C_1 (of N_1 turns) corresponding to the change of current I_2 in the coil C_2 (of N_2 turns).

8. Show that during the charging of parallel plate capacitor , the rate of change of charge on each plate equal to ϵ_0 times the rate of change of electric flux ϕ_E linked with it , and write the name of the $\epsilon_0 \frac{d\phi_E}{dt}$.

9. Write three differences between interference and diffraction of light .

10. The radionuclide ${}^{11}_6\text{C}$ decay according to ${}^{11}_6\text{C} \rightarrow {}^{11}_5\text{B} + e^+ + \nu + Q$, $T_{1/2}=20.3$ min

The minimum energy of the emitted positron is 0.960MeV. Given the mass values .

$m({}^{11}_6\text{C})=11.0114344\text{u}$ and $m({}^{11}_5\text{B})=11.009305\text{u}$

Calculate Q and compare it with the maximum energy of the positron emitted .

SECTION – C

11. State and prove the Gauss theorem in Electrostatics .

12. Use Kirchhoff's rules to determine the potential difference between the points A and D when no current flows in the arm BE of the electric network .

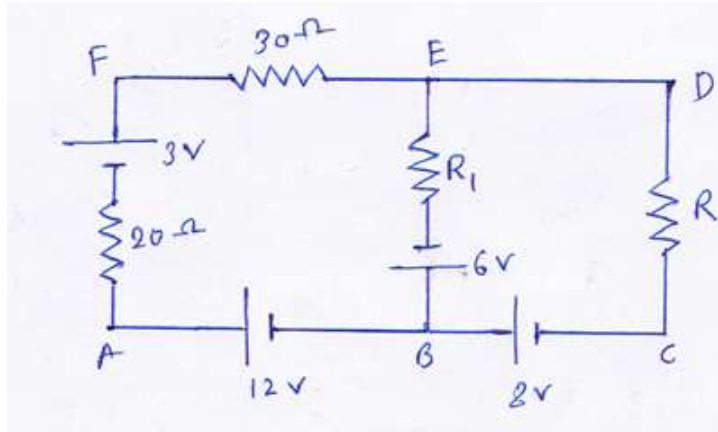

13. One charge Particle q moving in a straight line is accelerated by a potential difference V . It enters a uniform magnetic field B perpendicular to its path . Derive an expression for radius of the path in which the particle travels .

Or , Apply Biot-savart's law to find the magnitude and direction of magnetic field due to a circular current carrying loop at a point on the axis of the loop .

14. A bar magnet M is dropped so that it falls vertically through the coil C . The graph obtained for voltage produced across the coil vs. time is :

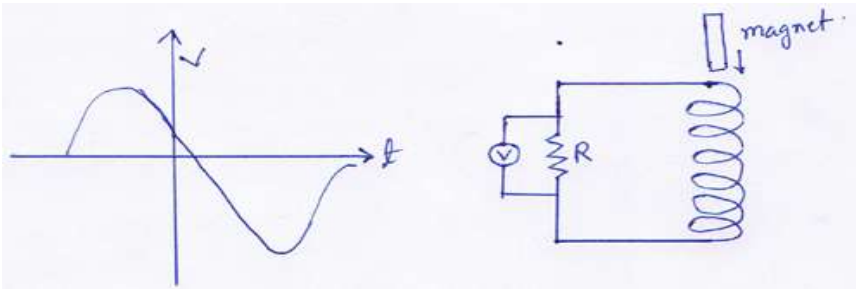

(i) explain the shape of the graph .

(ii) why is the negative peak is longer than the positive peak ?

15. Answer the following questions:

a) The small ozone layer on top of the stratosphere is crucial for human survival. Why ?

b) Long distance radio broadcasts uses short –wave bands . Why ?

c) Name the Indian scientist who first produced the electromagnetic waves ?

16. a card sheet divided into square each of size 1mm^2 is being viewed at a distance 9cm held close to the eye .

a) what is the magnification produced by the lens ?

b) what is the angular magnification of the lens ?

c) is the magnification in a) equal to the magnifying power in b) ? explain .

17. Show graphically the variation of intensity with angle of diffraction patterns at a single slit .

Find the ratio of intensities of two points P and Q on a screen in a Young's double slit experiment when waves from sources S_1 and S_2 have phase differences of (i) $\frac{\pi}{2}$ and (ii) $-\frac{\pi}{2}$ respectively.

18. a) What do you mean by dual nature of matter ?

b) What is de-Broglie wavelength of a nitrogen molecule in air at 300K ? Assume that the molecule is moving with the rms speed of molecules at this temperature . (atomic mass of nitrogen =14.0076u , $K = 1.38 \times 10^{-23} \text{JK}^{-1}$)

19. a) What is forward and reverse bias of p-n junction diode ?

b) Draw figure diagram to show the change of depletion layer and energy barrier in two cases .

c) write truth table of the circuit.

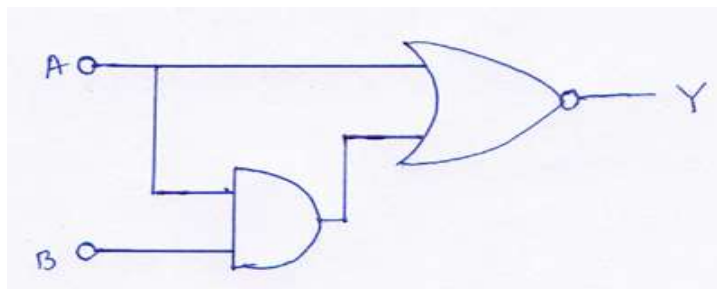

20. What is skip distance ?

By what percentage will the transmission range of a TV tower be affected when the height of the tower is increased by 21% ?

21.a) What is electric flux ? Give SI unit .

b) The electric field in a region can be expressed by $\vec{E} = \left[\frac{3}{5}\hat{i} + \frac{4}{5}\hat{j} \right] \times 2 \times 10^3 \text{ NC}^{-1}$

Determine the flux of this field through a regular surface of area 0.2 m^2 situated parallel to the Y-Z plane .

22. On what principle the parallel plate capacitor work ? Determine the expression of electric potential energy stored in a charged capacitor .

SECTION –D

23. Kartik watching a program on MOON on Discovery channel . He was surprised to know that the sky appeared dark if observed from the surface of moon . He shared this information with his friends but was not happy with the answers given by them . nex day he asked his physics teacher whether the information was correct and what was the exact reason for the same . the teacher gladly gave the exact explanation to all the students .

Answer the following questions :

(i) Name two phenomenon of light responsible for above information about sky appearing dark when observed from moon surface . Give one more example of each of these phenomenon .

(ii) Which two values reflected by Kartik's behavior ?

(iii) Give an example of another similar information you might have come across suddenly while watching some program on TV .

SECTION – E

24. a) A biconvex lens with its two faces of equal radius of curvature R is made of a transparent medium of refractive index μ_1 . It is kept in contact with a medium of refractive index μ_2 as shown in figure ;

(i) Find the equivalent focal length of the combination .

(ii) Obtain the condition when this combination acts as a diverging lens .

b) Draw the ray diagram for the case $\mu_1 > \frac{(\mu_2 + 1)}{2}$, when the object is kept far away from the nature of the image formed by the system .

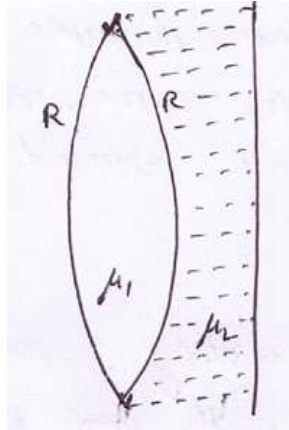

or, a) Draw a graph showing the variation of intensity of polarized light transmitted by an analyzer .

b) A Cassegrain telescope uses two mirrors as shown in fig . Such a telescope is built with the mirrors 200mm apart . If the radius of curvature of the large mirror is 140mm , where will the final image of an object at infinity be ?

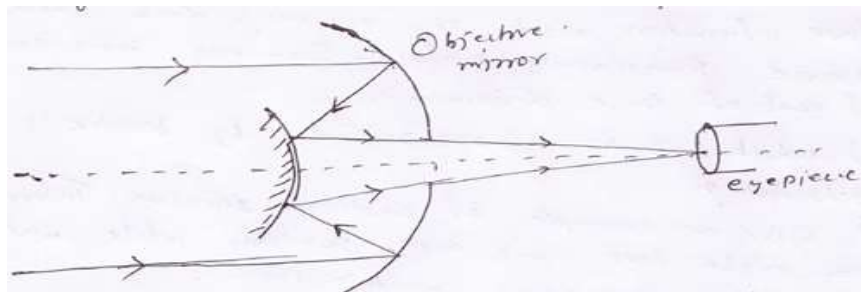

25. a) Both alternating current and direct current are measured in amperes . But how is the ampere defined for alternating current ?

b) Draw a schematic sketch of an ac generator describing its basic elements . Show a plot of variation of (i) Magnetic flux and (ii) Alternating emf versus time generated by a loop of wire rotating in a magnetic field .

c) Why is Chocke coil needed in the use of fluorescent tubes with an ac mains ?

or , a) State and explain Lenz's law to find direction of induced current .

b) A wheel with 8 metallic spokes each 50cm long is rotated with a speed of 120rev/min in a plane normal to the horizontal component of the earth's magnetic field . The earth's magnetic field at place is 0.4G and the angle of dip is 60° . Calculate the emf induced between the axel and the rim of the wheel . How will the value of emf be affected if the number of spokes were increased ?

26. a) State the principle of superposition of charge . Hence express the force on a charge 'q' due to discrete distribution of n charges in terms of their position vectors .

b) write three properties of electric lines of forces .

c) What quantity is represented by the unit JC^{-1} ?

Or , a) Consider the situation shown in the fig. The capacitor A has charge 'q' on it , whereas B is uncharged .

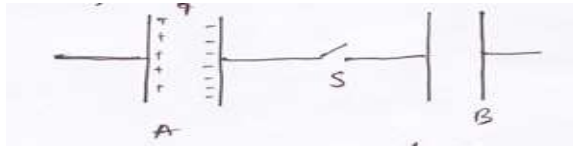

Explain what amount of charge will appear on the capacitor B long time after the switch s is closed .

b) if χ stands for the magnetic susceptibility of a given material , identify the class of material for which 1) $-1 \leq \chi < 0$ 2) $0 < \chi < \epsilon$ (ϵ stands for a small positive number)

(i) Write the range of relative magnetic permeability of these materials .

(ii) Draw the pattern of the magnetic field lines when these materials are placed in an external magnetic field .

Prepared By a CBSE school Teacher

Mr. Pintu Paul (PGT Physics)

M: 9436944941 / 70005282625