

CLASS XII

SAMPLE PAPER 2021

PHYSICS

TIME – 3 HRS + 15 MIN READING TIME

MM-70

General Instructions:

- (1) All questions are compulsory. There are 33 questions in all.
- (2) This question paper has five sections: Section A, Section B, Section C, Section D and Section E.
- (3) Section A contains ten very short answer questions and four assertion reasoning MCQs of 1 mark each, Section B has two case based questions of 4 marks each, Section C contains nine short answer questions of 2 marks each, Section D contains five short answer questions of 3 marks each and Section E contains three long answer questions of 5 marks each.
- (4) There is no overall choice. However internal choice is provided. You have to attempt only one of the choices in such questions.

SECTION – A

All questions are compulsory. In case of internal choices, attempt any one of them.

1. Show on a graph the variation of conductivity with temperature for a typical semiconductor?
2. What is the basic cause of electromagnetic induction?
3. What happens to self inductance when the number of turns of a coil per unit length is doubled?

OR

A lamp consumes only 50% of peak power in an a.c. circuit. What is the phase difference between the applied voltage and current

- 4 Name the part of emw and wavelength of signal having frequency of 300 megahertz?

5. Carbon, silicon and germanium have four valence electrons each. These are characterized by valence and conduction bands separated by energy band gap respectively equal to $(E_g)_C$, $(E_g)_{Si}$ and $(E_g)_{Ge}$. Arrange these in decreasing order of energy band gap.

OR

What is meant by minority carrier injection?

6. Which part of emw radiated by Human body ?

7. A nucleus ruptures into two nuclear parts which have their atomic mass ratio equal to 8: 1. What will be the ratio of their nuclear size (nuclear radius)?

8. If E_1, E_2, E_3 are the respective kinetic energies of electron, deuteron and proton having same De- Broglie wavelength. Rewrite these in increasing order of their magnitude.

OR

When radiation 5.6eV is incident on a metal surface, Photoelectron are ejected with kinetic energy 4eV , determine stopping potential.

9. An EM radiation has energy of 12.4keV . Identify which region of em spectrum has this energy?

10. A current carrying loop is placed in a uniform magnetic field in four different orientations, I, II, III & IV Which of these has minimum potential Energy?

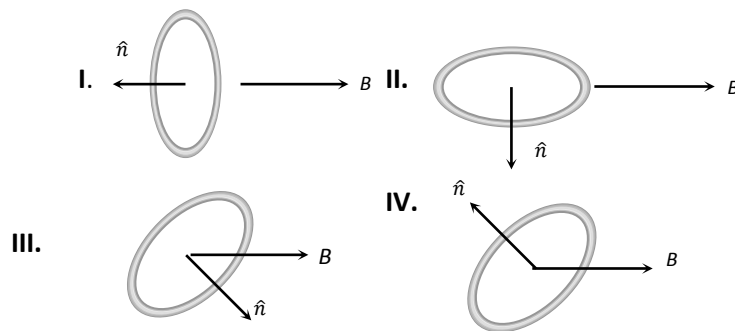

OR

Plot the variation of magnetic field due to a straight conductor of uniform cross section of radius a and carrying a steady current with distance r , in the region $r < a$ and $r > a$.

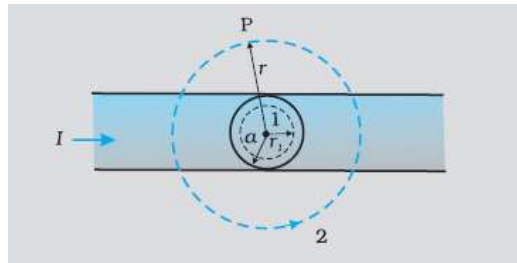

For question numbers 11, 12, 13 and 14, two statements are given-one labelled Assertion (A) and the other labelled Reason (R). Select the correct answer to these questions from the codes (a), (b), (c) and (d) as given below.

- a) Both A and R are true and R is the correct explanation of A
- b) Both A and R are true but R is NOT the correct explanation of A
- c) A is true but R is false
- d) A is false and R is also false

11. Assertion : If the distance between parallel plates of a capacitor is halved and dielectric constant is made three times, then the capacitor becomes 6 times.

Reason :Capacity of the capacitor does not depend upon the nature of the material .

12. Assertion : Electric field outside the conducting wire which carries a constant current is zero.

Reason :Net charge on conducting wire is zero.

13. Assertion : When a magnetic dipole is placed in a non uniform magnetic field, only a torque acts on the dipole.

Reason :Force would also acts on dipole if magnetic field were uniform.

14. Assertion : Self-inductance is called the inertia of electricity.

Reason : Self-inductance is the phenomenon, according to which an opposing induced e.m.f. is produced in a coil as a result of change in current or magnetic flux linked in the coil.

Section – B

Questions 15 and 16 are Case Study based questions and are compulsory. Attempt any 4 sub parts from each question. Each question carries 1 mark.

Q15. Optoelectronics

- In optoelectronics we deal with 2 types of electronic devices.
- Light emitting electronic devices: ones that generate electromagnetic energy under the action of electrical field. Example: light emitting diodes (visible and infrared light).
- Light detecting devices: ones that transform electromagnetic energy input into electrical current/voltage. Examples: photoresistors, photodiodes, etc.

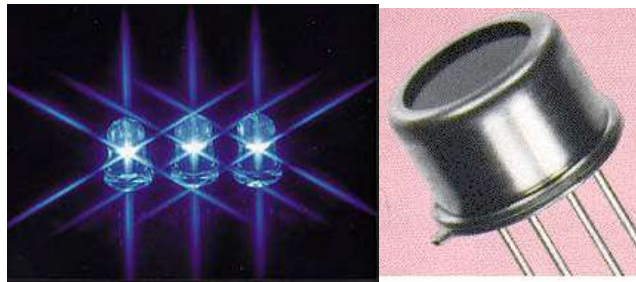

Light emitting diodes

PHOTO DIODE

Photodiode

- Photodiode is a semiconductor device that transforms light energy to electric energy. When photodiode is placed in dark, the current meter displays zero current flow. When the photodiode is exposed to light, it acts as a current source.
- Photodiodes have very linear light v/s current characteristics.

15.1. In the circuit, if the forward voltage drop for the diode is 0.5 V, the current will be

- (a) 3.4 mA
- (b) 2 mA
- (c) 2.5 mA

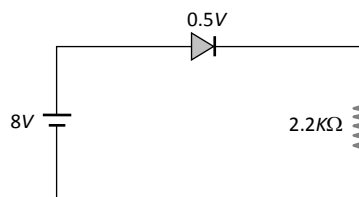

(d) 3 mA

15.2. In a *PN*-junction diode

- (a) The current in the reverse biased condition is generally very small
- (b) The current in the reverse biased condition is small but the forward biased current is independent of the bias voltage
- (c) The reverse biased current is strongly dependent on the applied bias voltage
- (d) The forward biased current is very small in comparison to reverse biased current

15.3. In the case of forward biasing of *PN*-junction, which one of the following figures correctly depicts the direction of flow of majority charge carriers of each side

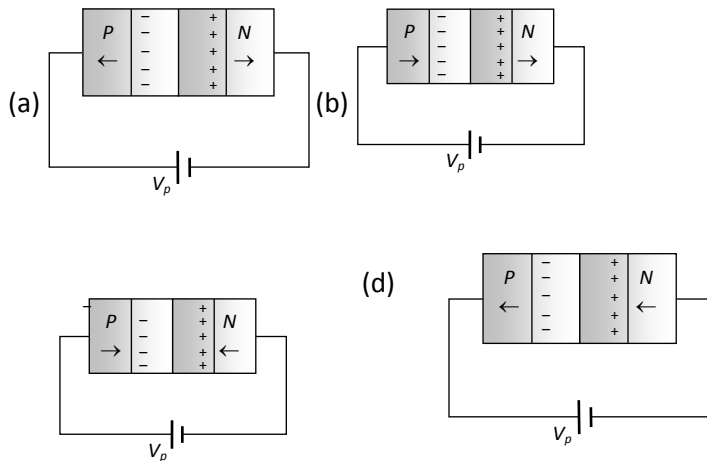

15.4. Symbolic representation of photodiode is

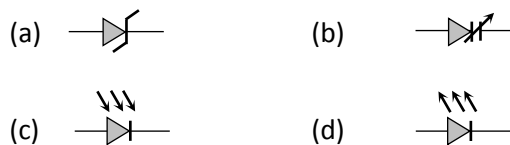

15.5. Chose correct option

- (a) A photo diode is forward biased and an LED is reverse biased
- (b) A photo diode is reverse biased and an LED is forward biased

- (c) both forward biased
- (d) both reverse biased

Q16. The lightning bolt

As a thundercloud billows, rising ice crystals collide with falling hailstones. The hail strips electrons from the rising ice and the top of the cloud becomes predominantly positive, while the bottom is mostly negative. Negative charges in the lower cloud repel negative charges on the ground. Electric fields build and a spark ignites a cloud-to-ground lightning flash through a potential difference of hundreds of millions of volts. The lightning bolt featured in Figure dramatically demonstrates that when a charge is placed in an electric field, it *will* move. The potential to move implies the existence of stored energy. Tremendous amounts of electric energy are “stored” in the electric fields created by the separation of charge between thunderclouds and the ground. This energy is often released in the “explosion” of a lightning bolt.



- 16.1. The insulated spheres of radii R_1 and R_2 having charges Q_1 and Q_2 respectively are connected to each other. There is
- (a) No change in the energy of the system
 - (b) An increase in the energy of the system
 - (c) Always a decrease in the energy of the system
 - (d) A decrease in the energy of the system unless $Q_1 R_2 = Q_2 R_1$

16.2. $+2C$ and $+6C$ two charges are repelling each other with a force of $12 N$. If each charge is given $-2C$ of charge, then the value of the force will be

- (a) $4N$ (Attractive) (b) $4N$ (Repulsive)
 (c) $8N$ (Repulsive) (d) Zero

16.3. What is the potential energy of the equal positive point charges of $1\mu C$ each held $1 m$ apart in air

- (a) $9 \times 10^{-3} J$ (b) $9 \times 10^{-3} eV$
 (c) $2eV/m$ (d) Zero

16.4. Two protons A and B are placed in space between plates of a parallel plate capacitor charged upto V volts (See fig.) Forces on protons are F_A and F_B , then

- (a) $F_A > F_B$
 (b) $F_A < F_B$
 (c) $F_A = F_B$
 (d) Nothing can be said

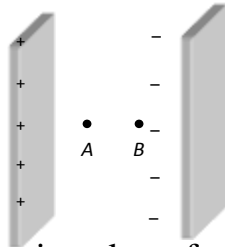

16.5. If a unit positive charge is taken from one point to another over an equipotential surface, then

- (a) Work is done on the charge
 (b) Work is done by the charge
 (c) Work done is constant
 (d) No work is done

Section – C

All questions are compulsory. In case of internal choices, attempt anyone.

17. Define eddy currents. What is its disadvantage?

OR

The magnetic flux linked with a coil varies with time as $\phi = 3t^2 + 4t + 9$ weber.
What is the induced emf at $t = 2s$?

18. Three identical dipoles are arranged as shown below. What will be the net electric field at P
($k = \frac{1}{4\pi\epsilon_0}$)

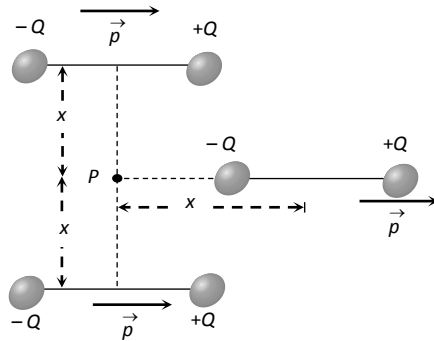

OR

Two metal spheres of radii R_1 and R_2 are charged to the same potential. Determine the ratio of charges and electric field on the spheres.

19. In the Rutherford scattering experiment the distance of the closest approach for an α particle is d_0 . If particle is replaced by a proton, how much K.E in comparison to α particle will it require to have the same distance of closest approach d_0 ?

20. Give two advantages of a light emitting diode (LED) over conventional incandescent lamps.

OR

Distinguish between 'P type' and 'N type' semi-conductors.

21. Differentiate between emf and terminal potential difference of a cell.

22. Use Bohr hypothesis and Rutherford's atomic model to Show that the radius of nth orbit in hydrogen atom varies as n^2 , where n is the principle quantum number of the orbit.

23. Explain sustained interference of light & how it can be achieved.

24. Derive an expression for magnetic dipole moment of a revolving electron around nucleus of Hydrogen atom and prove that magnetic dipole moment is opposite in direction to angular momentum of electron.
25. A beam of light of wavelength 420 nm, is used to obtain interference fringes in a Young's double-slit experiment. Find the distance of the third dark fringe on the screen from the central maxima. Take the separation between the slits as 4.2 mm and the distance between the screen and plane of the slits as 1.4 m.

Section -D

All questions are compulsory. In case of internal choices, attempt any one.

26. A plane wavefront propagating from a rarer into a denser medium is incident at an angle of incidence i on a refracting surface. Draw a diagram showing incident wavefront and refracted wavefront. Hence verify Snell's laws of refraction.
27. Prove that the current flowing through an ideal inductor connected across a.c. source, lags the voltage in phase by $\pi/2$. Show phasor diagram and wave form of Voltage and current.

OR

A wheel with 8 metallic spokes each 50 cm long is rotated with a speed of 120 rev/min in a plane normal to the horizontal component of the Earth's magnetic field. The Earth's magnetic field at the place is 0.4 G and the angle of dip is 60° . Calculate the emf induced between the axle and the rim of the wheel. How will the value of emf be affected if the number of spokes were increased ?

28. . Sketch the graph showing the variation of potential energy of a pair of nucleons as a function of their separation. Write three characteristic properties of nuclear force which distinguish it from the electrostatic force.
29. An optical instrument uses eye-lens of power 16 D and objective lens of power 50 D and has a tube length of 16.25 cm. Name the optical instrument , calculate its magnifying power if it forms the final image at infinity & draw proper ray diagram.

OR

(a) For a ray of light travelling from a denser medium of refractive index n_1 to a rarer medium of refractive index n_2 , prove that $n_1/n_2 = 1/\sin c$, where c is the critical angle for the media.

(b) Explain with the help of a diagram, how the above principle is used for transmission of video signals using optical fibres.

30. Light of intensity 'I' and frequency ' ν ' is incident on a photosensitive surface and causes photoelectric emission. What will be the effect on anode current when (i) the intensity of light is gradually increased, (ii) the frequency of incident radiation is increased, and (iii) the anode potential is increased? In each case, all other factors remain the same. Give justification in each case.

Section – E

All questions are compulsory. In case of internal choices, attempt any one.

31. In Young's double slit experiment, deduce the conditions for obtaining constructive and destructive interference fringes. Hence deduce the expression for the fringe width.

OR

Using glass prism derive relation between i , e , A and D where letters have their usual meaning and hence derive an expression for refractive index of glass prism.

(i) For a glass prism $\mu = \sqrt{3}$. the angle of minimum deviation is equal to the angle of the prism. Calculate the angle of the prism.

32. (a) A particle of charge q is moving with velocity v in the presence of crossed Electric field E and Magnetic field B as shown. Write the condition under which the particle will continue moving along x - axis. How would the trajectory of the particle be affected if the electric field is switched off?

