

## Physics 12<sup>th</sup> Guess Questions with answer for CBSE of Year 2021

### Electrostatics

#### VSA

1. Why do the electric field lines never cross to each other?

**Answer:**

When will do so, there will be two directions of electric field at the point of intersection, which is not possible.

2. An electrostatic field line cannot be discontinuous. Why?

**Answer:**

It represents the actual path of a unit positive charge, which experience a continuous force.

3. Figure shows the field lines on a positive charge. The work done by the field in moving a small positive charge from Q to P is positive or negative. Give reason.

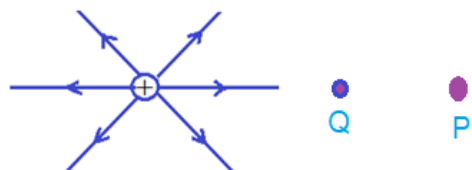

**Answer:**

Negative.

Because, the charge is displaced along the force exerted by the electric field.

4. Define the term 'dielectric constant' of a medium in terms of capacitance of a capacitor.

**Answer:**

**Dielectric constant:-** The ratio of electrical capacitance of capacitor with dielectric medium in between plates of a capacitor ( $C_m$ ) to the electrical capacitance of capacitor with air or vacuum in between the plates of capacitor ( $C_0$ ) is called dielectric constant (K).

$$\text{i.e. } K = \frac{C_m}{C_0}$$

5. What is the electric flux through a cube of side 1 cm which encloses an electric dipole?

**Answer:**

The net charge of an electric dipole is zero. Hence, the electric flux through a given cube will be zero?

6. Does the charge given to a metallic sphere depend on whether it is hollow or solid?

**Answer:**

No, the capacity of spherical conductor is  $C = 4\pi\epsilon_0 R$  i.e. Capacity of spherical conductor depends on radius of spherical conductor.

7. What is the amount of work done in moving a point charge around a circular arc of radius  $r$ , where another point charge is located at the centre ?

**Answer:**

The potential at every point of circular arc is  $V = \frac{kq_1}{r}$ , i.e. The potential at every point of circular arc is equal.

$$\therefore \text{Required work done, } W = q_2(V_1 - V_2) = q_2(V - V) \\ = q_2 \times 0 = \text{zero.}$$

8. Two dipoles, made from charges  $\pm q$  and  $\pm Q$  respectively, have equal dipole moments. Give the (i) ratio between separation of these two pairs of charges, (ii) angle between the dipole axis of these two dipoles.

**Answer:**

(i) Since  $p_1 = p_2$  Or  $q \times l_1 = Q \times l_2$  Or  $\frac{l_1}{l_2} = \frac{Q}{q}$

(ii) Angle between the dipole axis of these two dipoles is zero.

9. How does the electric flux due to point charge enclosed by a spherical Gaussian surface get affected, when its radius is increased ?

**Answer:**

Since,  $\phi_B = \frac{q_{net}}{\epsilon_0}$ , therefore electric flux will remain unaffected ?

10. Two charges of magnitudes  $-2Q$  and  $+Q$  are located at points  $(a, 0)$ ,  $(4a, 0)$  respectively. What is electric flux due to these charges through a sphere of radius  $3a$  with its centre at the origin ?

**Answer:**

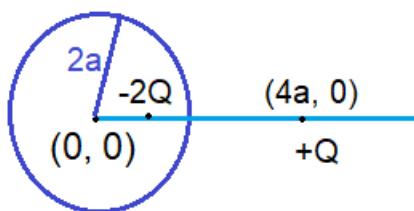

The net charge enclosed by sphere of radius  $3a = -2Q$  .

$$\therefore \text{Electric flux, } \phi_E = \frac{\text{net charge}}{\epsilon_0} = \frac{-2Q}{\epsilon_0}$$

11. What is the geometrical shape of equipotential surface due to a single isolated charge ?

**Answer:**

Concentric spherical surfaces as shown in the figure.

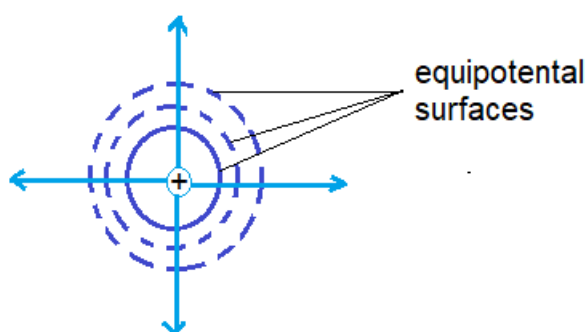

12. Why are electric field lines perpendicular at a point on an equipotential surface of a conductor ?

**Answer:**

If it were not so, the presence of a component of the field along the surface would violate its equipotential nature.

13. A charge  $q$  is moved from a point A above a dipole of dipole moment  $p$  to a point B below the dipole, in equatorial plane without acceleration. Find the work done in the process.

**Answer:**

On the equatorial line of a dipole, the electric potential is zero. Therefore, required work done without acceleration ( $W = Vq$ ) will be zero.

14. Force of attraction between two point charges placed at a distance  $d$  is  $F$ . What distance apart should they be kept in the same medium so that force between them is  $F/3$  ?

**Answer:**

Since Force at distance  $d$  ,  $F = k \frac{q_1 q_2}{d^2}$  ..... (i)

Let force becomes  $\frac{F}{3}$  at distance  $x$ .

$$\therefore \frac{F}{3} = k \frac{q_1 q_2}{x^2}$$
 ..... (ii)

Dividing equation (i) by equation (ii),

$$\frac{F}{F/3} = \frac{x^2}{d^2} \Rightarrow 3 = \frac{x^2}{d^2} \Rightarrow x^2 = 3d^2$$

$$\therefore x = \sqrt{3d^2} = \sqrt{3} d \text{ SI units}$$

15. In which orientation, a dipole placed in uniform magnetic field is in (i) stable equilibrium (ii) unstable equilibrium ?

**Answer:**

For stable equilibrium angle ( $\theta$ ) between  $\vec{p}$  and  $\vec{E}$  should be zero

For unstable equilibrium angle ( $\theta$ ) between  $\vec{p}$  and  $\vec{E}$  should be  $180^\circ$

16. At what points, electric field intensity of an electric dipole is parallel to the line joining the charges?

**Answer:**

At any point on axial line or equatorial line of the dipole.

17. A hollow metal sphere of radius 5 cm is charged such that potential on its surface is 20 volt. What is the potential at the centre of the sphere?

**Answer:**

The potential at every points inside the hollow sphere is equal to the potential at on the surface of sphere.

$\therefore$  Potential at centre of hollow sphere will 20 volt.

18. Two plane sheets of charge densities  $+\sigma$  and  $-\sigma$  are placed in air as shown in the figure.

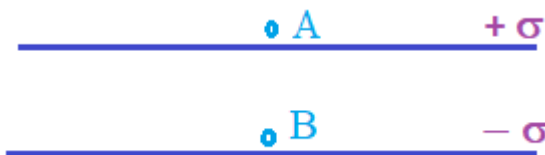

S

What are the electric field intensities at points A and B ?

**Answer:**

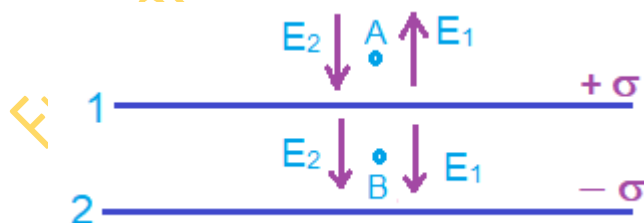

$$\text{At point A, } E = E_1 - E_2 = \frac{\sigma}{2\epsilon_0} - \frac{\sigma}{2\epsilon_0} = 0$$

$$\text{At point B, } E = E_1 + E_2 = \frac{\sigma}{2\epsilon_0} + \frac{\sigma}{2\epsilon_0} = \frac{\sigma}{\epsilon_0}$$

19. What is the work done in moving a test charge  $q$  through a distance of 2 cm along the equatorial axis of an electric dipole ?

**Answer:**

On equatorial line of a dipole , electric potential  $V = 0$

$$\therefore W = qV = 0$$

20. Figure shows three point charges  $+2q$  ,  $-q$  and  $+3q$  . What is the electric flux due to this configuration through the surface  $S$  ?

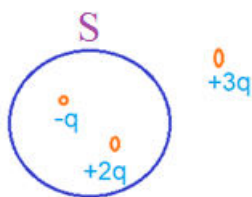

**Answer:**

$$\phi_E = \frac{Q_{net}}{\epsilon_0} \text{ Where } Q_{net} = \text{net charge inside the surface } S.$$

$$= \frac{+2q - q}{\epsilon_0} = \frac{q}{\epsilon_0}$$

21. Draw an equipotential surface for a uniform electric field.

**Answer:**

For a uniform electric field , assumed along X- axis, the equipotential surfaces are planes normal to the X- axis and parallel to the Y-Z plane as shown in the figure.

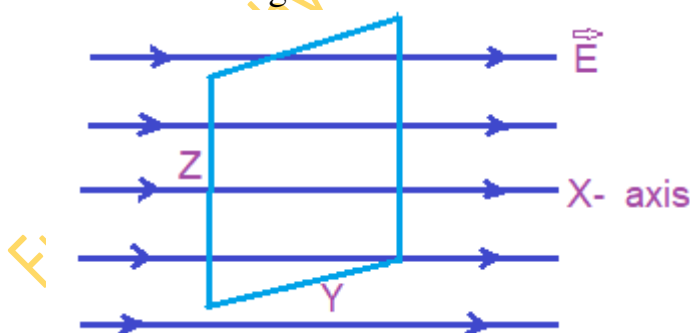

22. Can a metallic sphere of radius 4 cm acquire 1 C of charge? Justify your answer.

**Answer:**

Potential produced due to this charge,

$$V = \frac{Kq}{r} = \frac{9 \times 10^9 \times 1}{4 \times 10^{-2}} = 2.25 \times 10^{11} \text{ volt. } \gg \text{breakdown field of air about } 3 \times 10^6 \text{ V/m. Therefore, whole charge will leak out.}$$

Hence, a metallic sphere of radius 4 cm can not acquire 1 C of charge.

23. Sketch a graph to show how charge Q given to a capacitor of capacity C varies with the potential difference V.

**Answer:**

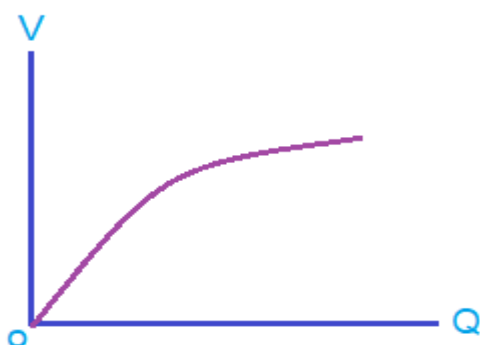

Initially the graph between V and Q is a straight line. But, beyond a certain stage, charge from plate of capacitor starts leakage and V does not increase with increase of Q.

24. Why does the electric field inside a dielectric decrease, when it is placed in an external electric field?

**Answer:**

In presence of an external electric field, opposite electric field induces inside dielectric medium. Due to this, electric field inside a dielectric decreases.

25. What is the relation between dielectric constant and electric susceptibility ?

**Answer:**

$$k = 1 + \chi_e$$

where k = dielectric constant and  $\chi_e$  = electrical susceptibility.

### Fill in the blanks

1. Two point charges of equal magnitude of 1 coulomb exert a force ..... mutually, when they are placed 1m apart in air.

**Answer:**

$$9 \times 10^9 \text{ N}$$

2. If a net charge exists outside a closed surface, the net electric flux linked with the closed surface will be .....

**Answer:**

zero

**Explanation:**

The net electric flux linked with the closed surface,

$$\phi_B = \frac{q_{net}}{\epsilon_0} = \frac{0}{\epsilon_0} = 0$$

Where  $q_{net}$  = net charge inside a closed surface.

3. The maximum value of electric field that a dielectric medium can tolerate without its electric break down is called its .....

**Answer:**

Dielectric strength

4. The distance between the two plates of an isolated charged air parallel plate capacitor is increased. The potential difference between the plate will be .....

**Answer:**

Increases

**Explanation:**

$$V = \frac{q}{C} \dots \dots (i)$$

For air parallel plate capacitor ,  $C = \frac{\epsilon_0 A}{d}$

∴ From equation (i),  $V = \frac{qd}{\epsilon_0 A}$  this implies  $V \propto d$

5. The value and units of  $\epsilon_0$  are ..... and .....

**Answer:**

$8.85 \times 10^{-12} ; C^2 N^{-1} m^{-2}$ .

6. The electric field at a point near an infinite thin sheet of charged conductor is .....

**Answer:**

$$\frac{\sigma}{2\epsilon_0}$$

7. The electric potential inside positively charged hollow spherical conductor is ..... and .....

**Answer:**

Positive ; uniform

8. The electric field intensity at distance  $r$  on the axis of an electric dipole is  $E_1$  and on the perpendicular bisector axis of dipole is  $E_2$ . The angle between  $E_1$  and  $E_2$  is  $\theta$ . Then  $E_1 : E_2$  and  $\theta$  will be ..... and .....

**Answer:**

2:1;  $\pi$

**Explanation:**

$$\frac{E_{axis}}{E_{eq}} = \frac{2}{1} = 2 : 1$$

Again direction of  $E_{axis}$  along X-axis,  
And direction of  $E_{eq}$  is along  $X'$ - axis.

$$\text{Hence } \theta = 180^\circ = \pi$$

9. An electric dipole is placed in a uniform electric field with its axis parallel to the field. It experiences .....

**Answer:**

Neither a net force nor a torque.

10. The electrostatic force between two point charges kept at a distance  $d$  apart, in a medium  $\epsilon_r = 4$ , is 0.8 N. The force between them at the same distance in vacuum will .....

**Answer:**

3.2N

**Explanation:**

$$\epsilon_r = \frac{F_0}{F_m} \quad \text{or} \quad F_0 = \epsilon_r F_m = 4 \times 0.8 = 3.2\text{N}$$

11. The electric field intensity at a distance of 4 m from a point charge is  $200 \text{ V m}^{-1}$ . It will be  $400 \text{ V m}^{-1}$  at a distance of .....

**Answer:**

$2\sqrt{2} \text{ m}$ .

**Explanation:**

$$E = \frac{Kq}{r^2}. \text{ Therefore } \frac{E_1}{E_2} = \frac{Kq}{r_1^2} \times \frac{r_2^2}{Kq} = \frac{r_2^2}{r_1^2} \quad \text{or} \quad r_2^2 = \frac{E_1}{E_2} \times r_1^2$$

$$= \frac{200}{400} \times 4^2 = 8 \quad \text{or} \quad r_2 = \sqrt{8} = 2\sqrt{2} \text{ m}$$



12. Electrons are transferred from the material whose ..... is ..... to the material whose ..... is .....
- Answer:**  
Work function ; lower ; work function ; higher.
13. The electric lines of force are ..... as against magnetic lines of force which are .....
- Answer:**  
Discontinuous ; continuous.
14. Electric flux is a ..... and its units are .....
- Answer:**  
Scalar ;  $Nm^2C^{-1}$ .
15. Throughout the volume of the conductor, electric potential is ..... and it has the ..... as on its surface.
- Answer:**  
Constant ; same value
16. When plates of a capacitor are separated by a dielectric medium of relative permittivity  $k$ , instead of air, ..... Becomes ..... times.
- Answer:**  
Its capacity ;  $k$
17. When charges are shared between any two bodies, their ..... become .....and ..... is really lost , but ..... does occur.
- Answer:**  
Potentials ; same ; no charge ; some energy loss.

### Assertion –reason Type Questions

Following questions have two statements - one labelled Assertion (A) and the other labelled Reason (R).

Select the correct answer to these questions from the codes (a), (b), (c) and (d) as given below.

- a) Both A and R are true and R is the correct explanation of A
- b) Both A and R are true but R is NOT the correct explanation of A
- c) A is true but R is false
- d) A is false and R is also false

#### 1. Assertion (A)

In a non-uniform electric field, a dipole will have translatory as well as rotatory motion.

**Reason (R)**

In a non-uniform electric field, a dipole experiences a force as well as torque.

**Correct option:**(a)

**2. Assertion (A)**

Electric field is always normal to equipotential surface and along the direction of decreasing order of potential.

**Reason (R)**

Negative gradient of electric potential is electric field.

**Correct option:**(b)

**3. Assertion (A)**

Electrons move away from a region of lower potential to a region of higher potential.

**Reason (R)**

Since an electron has a negative charge.

**Correct option:** (a)

**4. Assertion (A)**

During charging by rubbing, the insulating material with lower work function becomes positively charged.

**Reason (R)**

Electrons are negatively charged.

**Correct option:** (b)

**5. Assertion (A)**

A metallic shield in the form of a hollow shell, can be built to block an electric field

**Reason (R)**

In a hollow spherical shell, the electric field at every point inside the shell is not zero.

**Correct option:** (c)

**6. Assertion (A)**

If a point charge  $q$  is placed in front of an infinite grounded conducting plane surface, the point charge will experience a force.

**Reason (R)**

This force is due to the induced charge on the conducting surface which is at zero potential.

**Correct option:** (a)

**7. Assertion (A)**

Capacity of a parallel plate capacitor remains unaffected on introducing a conducting or insulating slab between the plates.

**Reason (R)**

In both the cases, electric field intensity between the plates increases.

**Correct option:** (d)

**8. Assertion (A)**

Faraday is too big a unit of capacity.

**Reason (R)**

Capacity of the earth which is the largest sphere, is in microfarad.

**Correct option:** (a)

**9. Assertion (A)**

The work done in moving a charge between any two points in an electric field is independent of the path followed by the charge, between these points.

**Reason (R)**

Electrostatic force is non-conservative.

**Correct option:** (c)

**10. Assertion (A)**

The work done in moving any charge through any distance on an equipotential surface is zero.

**Reason (R)**

An equipotential surface is very smooth.

**Correct option:** (c)

**11. Assertion (A)**

When charges are shared between any two bodies, no charge is really lost, but some loss of energy does occur.

**Reason (R)**

Some energy disappears in the form of heat, sparking etc.

**Correct option:** (a)

**12. Assertion (A)**

The whole charge of a body cannot be transferred to another body.

**Reason (R)**

Charge cannot be transferred partially.

**Correct option:** (c)

**13. Assertion (A)**

Charge is quantized because only integral number of electrons can be transferred.

**Reason (R)**

There is no possibility of transfer of some fraction of electronic charge (charge on an electron).

**Correct option:** (a)

**Study based questions / Based on the given Passage**

Read the following passes carefully and choose the correct option of questions i, ii, iii and iv:

A Faraday case or Faraday shield is an enclosure made of conducting material. The field within a conductor cancel out with any external fields, so the electric field within the enclosure is zero. These Faraday cages act as big hollow conductors you can put things in to shield them from electrical fields. Any electrical shocks the case receives, pass harmlessly around the outside of outside of the cage.

(i) Which of the following material can be used to make a Faraday cage ?

- (a) Plastic (b) Copper (c) Wood (d) Glass

**Correct option:**(b)

(ii) Example of a real-world Faraday cage is

- (a) metal rod (b) plastic box (c) car (d) lighting rod

**Correct option:** (c)

(iii) What is the electrical force inside a Faraday cage when it is struck by lightning?

- (a) Half that of the lightning (b) The same as the lightning  
(c) A quarter of lightning (d) Zero

**Correct option:** (d)

(iv) An isolated point charge  $+q$  is placed inside the Faraday cage. Its surface must have charge equal to

- (a)  $+q$  (b)  $-q$  (c) zero (d)  $+2q$

**Correct option:** (a)

**SA (2 marks)**

1. An electric dipole is placed in uniform electric field at an angle  $\theta$  with the direction of field. Show that dipole will not done translator motion. Then, obtained expression for torque acting on the dipole.

**Answer:**

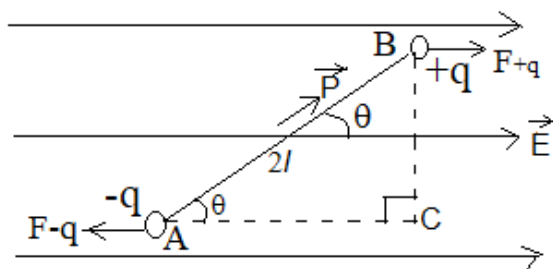

According to figure, electric force on charge +q of electric dipole due to uniform electric field will,

$$F_B = qE \dots\dots\dots (i) \text{ [ along } \vec{E} \text{ ]}$$

And electric force on charge -q of electric dipole due to uniform electric field will,

$$F_A = -qE \dots\dots\dots (ii) \text{ [ opposite to } \vec{E} \text{ ]}$$

$$\therefore \text{ Net force on dipole } F = F_B + F_A = qE - qE = 0$$

Hence, electric dipole will not done translator motion.

But, action lines of forces  $F_B$  and  $F_A$  are different. So, dipole will want to rotate.

$\therefore$  Torque acting on the dipole will,

$\tau = \text{magnitude of either force} \times \perp \text{ distance between forces.}$

$$= qE \times BC = qE \times AB \sin \theta$$

$$\text{ [ From triangle ABC, } \sin \theta = \frac{BC}{AB} \Rightarrow BC = AB \sin \theta \text{ ]}$$

$$= qE \times 2l \sin \theta = 2ql (E \sin \theta)$$

$$= PE \sin \theta$$

$$\therefore \tau = PE \sin \theta \dots\dots\dots (i)$$

$$\text{In vector form, } \vec{\tau} = \vec{P} \times \vec{E} \dots\dots\dots (ii)$$

2. A test charge q is moved without acceleration from A to C along the path from A to B and then from B to C in electric field E as shown in the figure,
  - (i) Calculate the potential difference between A and C will  $V_{AC} = E$
  - (ii) At what point (of the two) is the electric potential more and why?

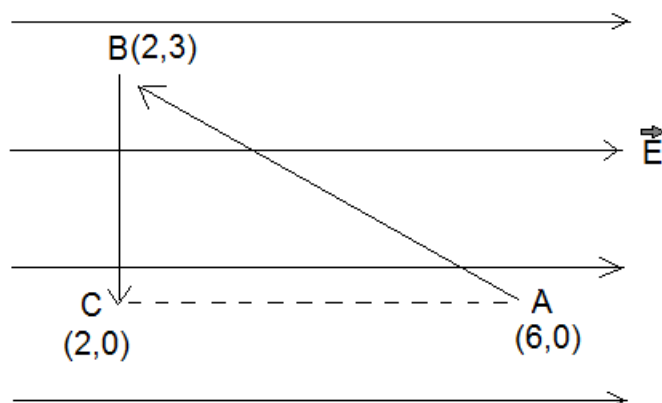

**Answer:**

(i) Potential difference between A and C will,

$$V_{AC} = -E dr = -E(6-2) = -4E$$

(ii) At point C, electric potential is more. Because along direction of electric field, electric potential decreases.

3. (a) Define the term 'electric flux'. Write its SI units.

(b) What is the flux due to electric field  $\vec{E} = 3 \times 10^3 \hat{i}$  N/C through a square of side 10 cm, when it is held normal to  $\vec{E}$ .

**Answer:**

(a) The electric lines of force (electric field) passing through a surface normally is called electric flux.

Its SI unit is newton metre<sup>2</sup> per coulomb (Nm<sup>2</sup>C<sup>-1</sup>).

(b) Given,  $E = 3 \times 10^3$  along X-axis,  $A = (0.1)^2 = 0.01$  m<sup>2</sup>,

$\theta =$  angle between  $\vec{E}$  and normal drawn on square =  $0^\circ$ ,  $\phi_B = ?$

$$\therefore \phi_B = EA \cos \theta = 3 \times 10^3 \times 0.01 \times \cos 0^\circ = 30 \text{ Nm}^2\text{C}^{-1}$$

4. Calculate the amount of work done in arranging a system of three charges

$6 \mu\text{C}$ ,  $6 \mu\text{C}$  and  $-6 \mu\text{C}$  placed on the vertices of an equilateral triangle of side 10 cm.

**Answer:**

Given,

$$q_1 = q_2 = 6 \mu\text{C} = 6 \times 10^{-6} \text{ C}, \quad q_3 = -6 \mu\text{C} = -6 \times 10^{-6}, \quad U = ?$$

$$\therefore U = \frac{K q_1 q_2}{r_{12}} + \frac{K q_1 q_3}{r_{13}} + \frac{K q_2 q_3}{r_{23}}$$

$$= \frac{9 \times 10^9 \times 6 \times 10^{-6} \times 6 \times 10^{-6}}{0.1} + \frac{9 \times 10^9 \times 6 \times 10^{-6} \times (-6 \times 10^{-6})}{0.1} +$$

$$\frac{9 \times 10^9 \times 6 \times 10^{-6} \times (-6 \times 10^{-6})}{0.1}$$

$$= 3.24 - 3.24 - 3.24 = - 3.24 \text{ J}$$

**LA-I (3 marks)**

1. (a) Obtain an expression for the torque  $\vec{\tau}$  experienced by an electric dipole of dipole moment  $\vec{p}$  in a uniform electric field  $\vec{E}$ .  
 (b) What will be happen if the field were not uniform?

Answer:

(a)

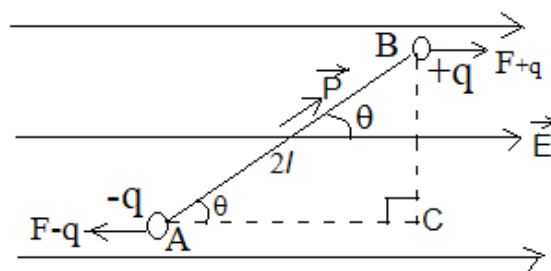

According to figure, electric force on charge +q of electric dipole due to uniform electric field will,

$$F_B = qE \dots\dots\dots (i) \quad [\text{along } \vec{E}]$$

And Electric force on charge -q of electric dipole due to uniform electric field will,

$$F_A = -qE \dots\dots\dots (ii) [\text{opposite to } \vec{E}]$$

∴ Net force on dipole,

$$F_{net} = F_B + F_A = qE - qE = 0$$

Hence, electric dipole will not done translator motion.

But, action lines of forces  $F_B$  and  $F_A$  are different. So, dipole will want to rotate.

∴ Torque acting on the dipole will,

$$\tau = \text{magnitude of either force} \times \perp \text{ distance between forces.}$$

$$= qE \times BC = qE \times AB \sin \theta$$

[ From triangle ABC,  $\sin \theta = \frac{BC}{AB} \Rightarrow BC = AB \sin \theta$  ]  
 $= qE \times 2l \sin \theta = 2ql (E \sin \theta)$   
 $= PE \sin \theta$

$\therefore \tau = PE \sin \theta$  ..... (i)

In vector form,  $\vec{\tau} = \vec{P} \times \vec{E}$  ..... (ii)

(b) When electric field is not uniform, then forces acting on the both charges are not equal. Therefore, net force and net torque on the dipole will non-zero.

Hence, dipole will do translator as well as rotatory motion.

2. State Gauss' theorem for electrostatics. Applying this theorem, derive an expression for the electric field intensity due to a uniformly charged spherical conducting shell at a point

(i) outside the shell and (ii) inside the shell.

Plot a graph showing variation of electric field as a function of  $r > R$  and  $r < R$

Where  $r$  is the distance from the centre of the shell.

Answer:

**Gauss' theorem:** The total electric flux linked with a closed surface is  $\frac{1}{\epsilon_0}$  times of net charge inside the closed surface ( $q_{net}$ ).

i.e.  $\phi_E = \oint_S \vec{E} \cdot \vec{dS} = \frac{q_{net}}{\epsilon_0}$

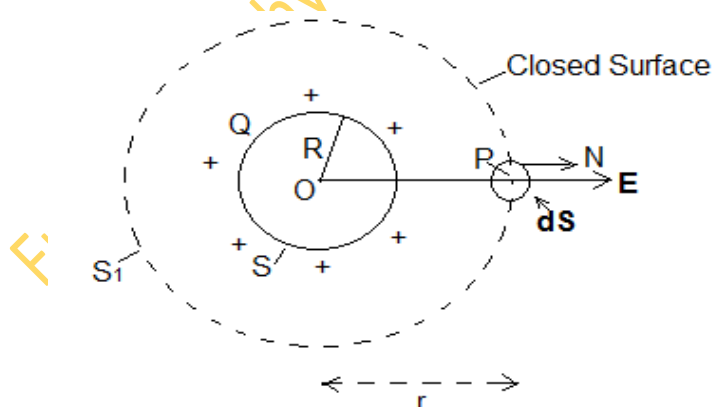

Consider a charged spherical shell of radius  $R$  placed in air or vacuum. Let we have to determine electric field intensity at point  $P$  outside the



shell at distance  $r$  from centre  $O$ . For this we imagine a spherical closed surface  $S_1$  of radius  $r$  such that point  $P$  is on the surface of  $S_1$ . The electric field intensity at every point on the surface of  $S_1$  is  $\mathbf{E}$  directed outside along radius. Let surface  $S_1$  is divide into many equal parts of area  $ds$ . Again, consider one area element  $d\mathbf{s}$ .

Now, total electric flux linked with closed surface  $S_1$  will,

$$\phi_E = \oint \vec{E} \cdot d\vec{S} = \oint E dS \cos \theta = \oint E dS \cos 0^\circ = \oint E dS = E \oint dS$$

$$= E \times \text{total area of closed surface } S_1$$

Or  $\phi_E = E \times 4\pi r^2 \dots\dots\dots (i)$

According to Gauss' theorem,  $\phi_E = \frac{q_{net}}{\epsilon_0} = \frac{Q}{\epsilon_0} \dots\dots\dots (ii)$

Comparing equations (i) and (ii), we get

$$E \times 4\pi r^2 = \frac{Q}{\epsilon_0}$$

$\therefore E = \frac{Q}{4\pi\epsilon_0 r^2} \dots\dots\dots (iii)$

This equation is same as electric field intensity due to a point charge. Hence charged spherical shell can be assumed as a point charge.

If point  $P$  is at inside the spherical shell, then  $q_{net} = 0$

$\therefore E \times 4\pi r^2 = \frac{q_{net}}{4\pi\epsilon_0 r^2} = \frac{0}{4\pi\epsilon_0 r^2} = 0$

Or  $E = 0$

A graph showing variation of electric field as a function of  $r$  is shown in the figure:

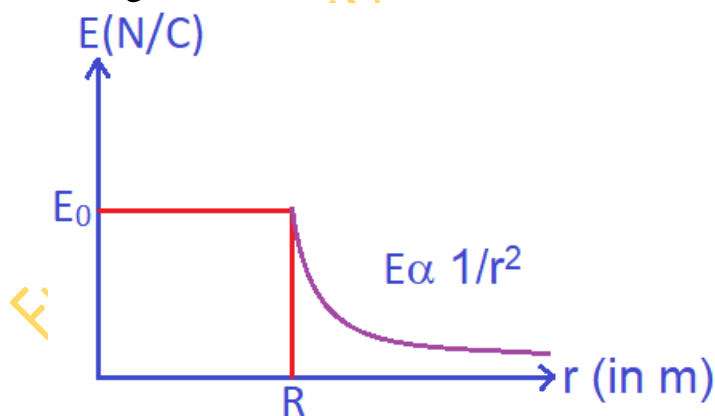

3. (a) Briefly explain the principle of a capacitor.
- (b) Derive an expression for the capacitance of a parallel plate capacitor, whose plates are separated by a dielectric medium partially.

Answer:

(a) **Principle of capacitor:-** when an earthed conductor plate is brought near to the unearthened conductor, then capacitance of unearthened conductor is increased extremely.

(b)

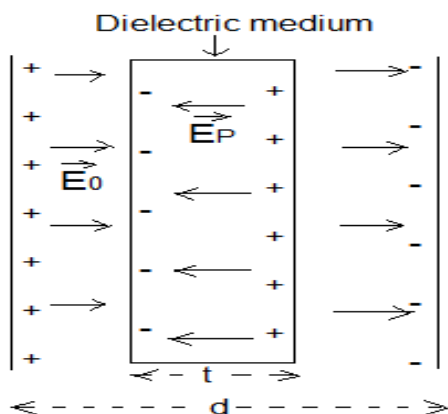

Suppose a dielectric medium of permittivity  $k$  and thickness  $t$  is placed in between plates of capacitor, where  $t < d$ .

$$\therefore k = \frac{E_0}{E} \Rightarrow E = \frac{E_0}{K} \dots\dots\dots (i)$$

Where  $E$  = electric field in dielectric medium and  $E_0$  = electric field in air.

$\therefore$  Potential difference between plates will,

$$\begin{aligned} V &= V_{\text{air}} + V_{\text{dielectric}} \\ &= E_0 (d - t) + E t = E_0 (d - t) + \frac{E_0}{K} t \quad [ \text{since } V = Ed ] \\ &= E_0 \left[ d - t + \frac{t}{K} \right] = \frac{\sigma}{\epsilon_0} \left[ d - t + \frac{t}{K} \right] \\ \Rightarrow V &= \frac{q}{\epsilon_0 A} \left[ d - t + \frac{t}{K} \right] \dots\dots\dots (ii) \quad [ \text{since } \sigma = \frac{q}{A} ] \end{aligned}$$

$\therefore$  Capacitance of capacitor will,

$$\begin{aligned} C &= \frac{q}{V} = \frac{q}{\frac{q}{\epsilon_0 A} \left[ d - t + \frac{t}{K} \right]} = \frac{\epsilon_0 A q}{q \left[ d - t + \frac{t}{K} \right]} = \frac{\epsilon_0 A}{d - t + \frac{t}{K}} \\ \Rightarrow C &= \frac{\epsilon_0 A}{d - t \left( 1 - \frac{1}{K} \right)} \dots\dots\dots (iii) \end{aligned}$$

4. Two parallel plate capacitors X and Y have the same area of plates and same separation between them. X has air between the plates while Y contains a dielectric medium of  $k = 4$ .

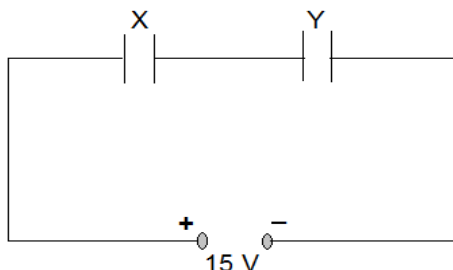

- (i) Calculate capacitance of each capacitor if equivalent capacitance of the combination is  $4 \mu\text{F}$ .  
 (ii) Calculate the potential difference between the plates of X and Y.  
 (iii) Estimate the ratio of electrostatic energy stored in X and Y.

**Answer:**

$$(i) C_s = 4 \mu\text{F} \text{ Or } \frac{C_1 \times C_2}{C_1 + C_2} = 4 \mu\text{F} \quad \text{Or } \frac{C \times kC}{C + kC} = 4 \mu\text{F}$$

$$\text{Or } \frac{C \times 4C}{C + 4C} = 4 \mu\text{F} \text{ Or } \frac{4C^2}{5C} = 4 \mu\text{F} \text{ Or } C = 5 \mu\text{F}$$

$$\therefore C_1 = 5 \mu\text{F} \text{ and } C_2 = kC = 4 \times 5 \mu\text{F} = 20 \mu\text{F}$$

(ii) Charge ( $q$ ) on each capacitor in series combination is same

$$\begin{aligned} \therefore q = C_s V &= 4 \mu\text{F} \times 15 = 4 \times 10^{-6} \times 15 \\ &= 60 \times 10^{-6} \text{ coulomb} = 0.6 \mu\text{C} \end{aligned}$$

$$\therefore V_1 = \frac{q}{C_1} = \frac{60 \times 10^{-6}}{5 \times 10^{-6}} = 12 \text{ volt}$$

$$\text{And } V_2 = \frac{q}{C_2} = \frac{60 \times 10^{-6}}{20 \times 10^{-6}} = 3 \text{ volt}$$

$$(iii) \frac{U_1}{U_2} = \frac{\frac{1}{2} C_1 V_1^2}{\frac{1}{2} C_2 V_2^2} = \frac{5 \times 10^{-6} \times 12^2}{20 \times 10^{-6} \times 3^2} = 4:1$$

5. A parallel plate capacitor of capacitance  $20 \mu\text{F}$  is connected to a  $100 \text{ V}$  supply. After sometime, the battery is disconnected, and the space between the plates of the capacitor is filled with a dielectric of dielectric constant 5. Calculate the energy stored in the capacitor.

(i) before (ii) after the dielectric has been put in between its plates.

Answer:

(i)  $C = 20 \mu\text{F} = 20 \times 10^{-6}\text{F}$ ,  $V = 100$  volt,  $E = ?$

$$\therefore E = \frac{1}{2} CV^2 = 0.5 \times 20 \times 10^{-6} \times 100^2 = 0.1 \text{ J}$$

(ii)  $C = 20 \mu\text{F} = 20 \times 10^{-6}\text{F}$ ,  $k = 6$ ,  $V = 100$  volt,  $E = ?$

$$\therefore E = \frac{1}{2} C_m V^2 = \frac{1}{2} kCV^2 \quad [C_m = kC]$$

$$= k \times \frac{1}{2} CV^2 = 5 \times 0.1 \text{ J} = 0.5 \text{ J}$$

6. A particle, having a charge  $+5 \mu\text{C}$ , is initially at rest at the point  $x = 30$  cm on the  $x$  axis. The particle begins to move due to the presence of a charge  $Q$  that is kept fixed at the origin. Find the kinetic energy of the particle at the instant it has moved 15 cm from its initial position if

(a)  $Q = +15 \mu\text{C}$  and (b)  $Q = -15 \mu\text{C}$

Answer:

(a)

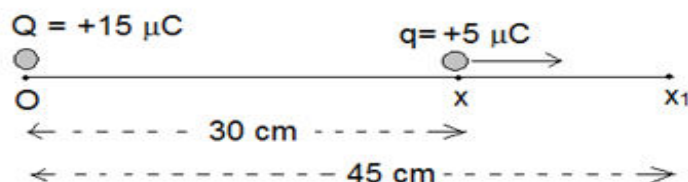

- (a) Kinetic energy of the particle at final position ( $x_1$ ) if  $Q = +15 \mu\text{C}$ ,

$$E_1 = Q(V_i - V_f) = Q \left( \frac{kq}{r_i} - \frac{kq}{r_f} \right) = kqQ \left( \frac{1}{r_i} - \frac{1}{r_f} \right)$$

$$= 9 \times 10^9 \times 5 \times 10^{-6} \times 15 \times 10^{-6} \left( \frac{1}{30 \times 10^{-2}} - \frac{1}{45 \times 10^{-2}} \right)$$

$$= 45 \times 15 \times 10^{-3} \left( \frac{100}{30} - \frac{100}{45} \right) = 45 \times 15 \times 10^{-3} \times \frac{100}{90} = 0.75 \text{ J}$$

- (b) Kinetic energy of the particle at final position ( $x_1$ ) if  $Q = -15 \mu\text{C}$ ,

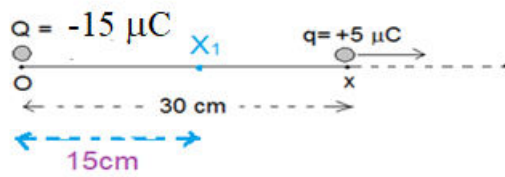

$$E_2 = 9 \times 10^9 \times 5 \times 10^{-6} \times 15 \times 10^{-6} \left( \frac{1}{30 \times 10^{-2}} - \frac{1}{15 \times 10^{-2}} \right)$$

$$= 45 \times 15 \times 10^{-3} \left( \frac{100}{30} - \frac{100}{15} \right) = 45 \times 15 \times 10^{-3} \times \frac{-100}{30} = -2.25 \text{ J}$$

7. (a) Obtain equivalent capacitance of the following network given in the figure below.
- (b) For a 300 V supply, determine the charge and voltage across each capacitor.

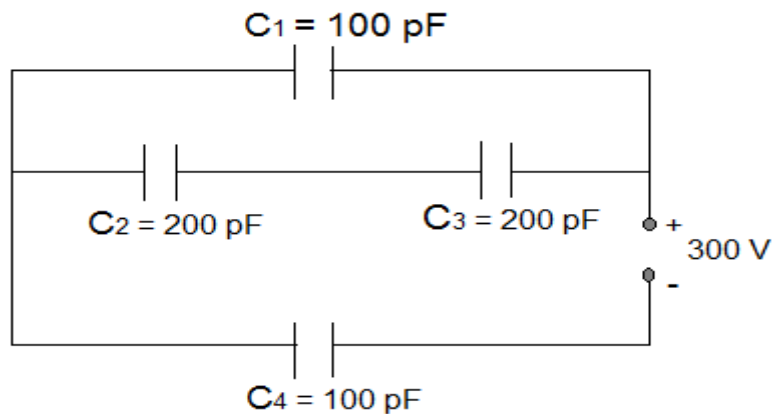

Answer:

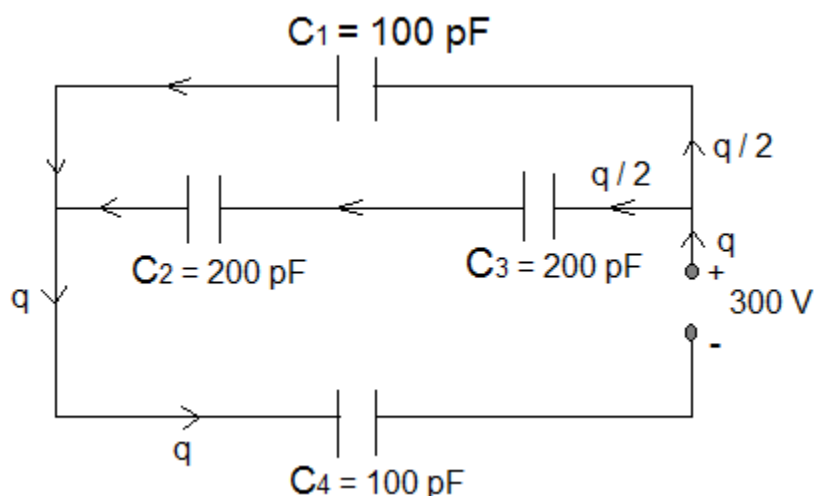

(a) Equivalent capacitance of  $C_2$  and  $C_3$  is

$$C_{23} = \frac{C_2 \cdot C_3}{C_2 + C_3} = \frac{200 \times 200}{200 + 200} = \frac{200 \times 200}{2 \times 200} = 100 \text{ pF}$$

$C_{23}$  is connected with capacitor  $C_1$  in parallel.

Therefore, equivalent capacitance of  $C_{23}$  and  $C_1$  will,

$$C_{123} = C_{23} + C_1 = 100 \text{ pF} + 100 \text{ pF} = 200 \text{ pF}$$

Again,  $C_{123}$  is connected with  $C_4$  in series.

$\therefore$  Equivalent capacitance of Circuit will,

$$C = \frac{C_{123} \times C_4}{C_{123} + C_4} = \frac{200 \times 100}{200 + 100} = \frac{200 \times 100}{300} = \frac{200}{3} \text{ pF}$$

(b) Charge flowing in the circuit will,

$$q = CV = \frac{200}{3} \text{ pF} \times 300 \text{ V}$$

$$= \frac{200}{3} \times 10^{-12} \times 300 \text{ V} = 2 \times 10^{-8} \text{ coulomb}$$

Since charge does not distribute in series,

$\therefore$  Charge on each plate of  $C_{123}$  and  $C_4 = 2 \times 10^{-8}$  coulomb

i.e.  $q_{123} = q_4 = 2 \times 10^{-8}$  coulomb

Again, charge distribute equally in parallel, when they are of equal capacitances

$\therefore$  Charge on each plate of  $C_1$  and  $C_{23} = \frac{q}{2} = \frac{2 \times 10^{-8}}{2} = 10^{-8}$  coulomb

i.e.  $q_1 = q_2 = q_3 = 10^{-8}$  coulomb

Now, voltage across  $C_1$  will,  $V_1 = \frac{q_1}{C_1} = \frac{10^{-8}}{100 \times 10^{-12}} = 100$  volt

Voltage across  $C_2$  will,  $V_2 = \frac{q_2}{C_2} = \frac{10^{-8}}{200 \times 10^{-12}} = 50$  volt

Voltage across  $C_3$  will,  $V_3 = \frac{q_3}{C_3} = \frac{10^{-8}}{200 \times 10^{-12}} = 50$  volt

And voltage across  $C_4$  will,  $V_4 = \frac{q_4}{C_4} = \frac{2 \times 10^{-8}}{100 \times 10^{-12}} = 200$  volt

8. Four point charges  $Q, q, Q$  and  $q$  are placed at the corners of a square of side 'a' as shown in the figure.

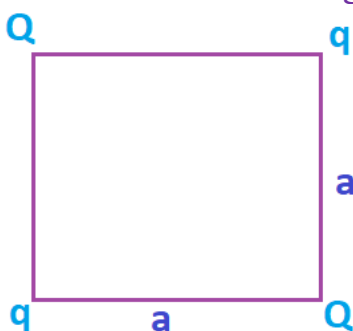

Find the (a) resultant electric force on charge  $Q$  and (b) potential energy of this system.

Answer:

(a)

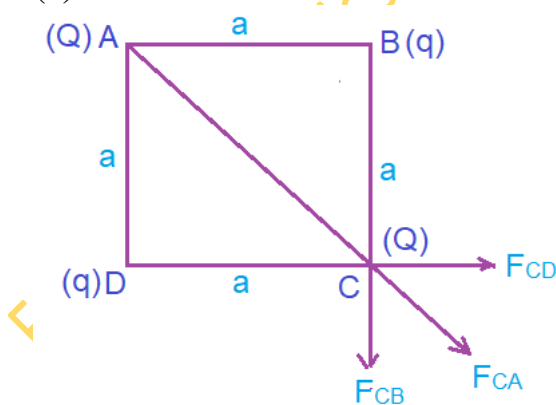

Electric force on charge  $Q$  at corner  $C$  due charge  $q$  at corner  $B$ ,

$$F_{CB} = \frac{k q_1 q_2}{r^2} = \frac{K Q q}{a^2} = F \text{ (let) along BC produced}$$

Electric force on charge  $Q$  at corner  $C$  due charge  $q$  at corner  $D$ ,

$$F_{CD} = \frac{KQq}{a^2} = F \text{ along DC produced}$$

Resultant force of  $F_{CB}$  and  $F_{CD}$  will,

$$F_{CBD} = \sqrt{F^2 + F^2} = \sqrt{2F^2} = \sqrt{2} F \text{ along AC produced}$$

Electric force on charge Q at corner C due charge Q at corner A,

$$F_{CA} = \frac{Kq_1q_2}{r^2} = \frac{KQ \cdot Q}{(\sqrt{2}a)^2} = \frac{KQ^2}{2a^2} \text{ along AC produced}$$

$$\therefore \text{Net force on charge Q at corner at C} = \sqrt{2} F + \frac{KQ^2}{2a^2}$$

$$= \sqrt{2} \frac{KQq}{a^2} + \frac{KQ^2}{2a^2} = \frac{KQ}{a^2} (\sqrt{2} q + Q/2) \text{ along AC produced}$$

(b) Potential energy of system,

$$\begin{aligned} U &= \frac{KQq}{r_{AB}} + \frac{KQ \cdot Q}{r_{AC}} + \frac{KQq}{r_{AD}} + \frac{KqQ}{r_{BC}} + \frac{Kq \cdot q}{r_{BD}} + \frac{KQq}{r_{CD}} \\ &= \frac{KQq}{a} + \frac{KQ \cdot Q}{\sqrt{2}a} + \frac{KQq}{a} + \frac{KQq}{a} + \frac{Kq^2}{\sqrt{2}a} + \frac{KQq}{a} \\ &= 4 \frac{KQq}{a} + \frac{KQ \cdot Q}{\sqrt{2}a} + \frac{Kq^2}{\sqrt{2}a} = 4 \frac{KQq}{a} + \frac{KQ^2}{\sqrt{2}a} + \frac{Kq^2}{\sqrt{2}a} \\ &= \frac{K}{a} \left( 4Qq + \frac{Q^2}{\sqrt{2}} + \frac{q^2}{\sqrt{2}} \right) \end{aligned}$$

9. (a) Three point charges  $q$ ,  $-4q$  and  $2q$  are placed at the vertices of an equilateral triangle ABC of side 'x' as shown in the figure. Obtain the expression for the magnitude of the resultant electric force acting on the charge  $q$ .

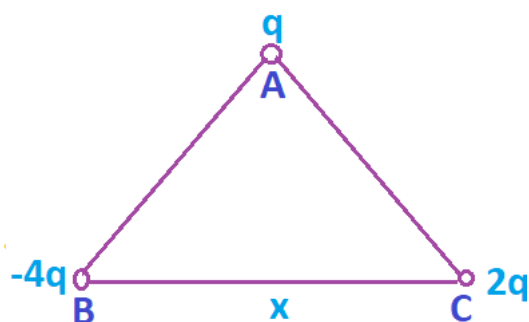

(b) Find out the amount of the work done to separate the charges at infinite distance.

**Answer:**

Electric force on charge  $q$  at corner A due to charge ( $2q$ ) at corner C,



$$F_{AC} = \frac{k |q_1| \cdot |q_2|}{r^2} = \frac{K 2q \cdot q}{x^2} = \frac{2Kq^2}{x^2} \text{ along CA produced}$$

Electric force on charge q at corner A due to charge (-4q) at corner B,

$$F_{AB} = \frac{k |-4q| \cdot |q|}{r^2} = \frac{K 4q \cdot q}{x^2} = \frac{4Kq^2}{x^2} \text{ along AB}$$

Angle between  $\vec{F}_{AC}$  and  $\vec{F}_{AB}$  is  $120^\circ$

$\therefore$  Resultant force on charge q will,

$$\begin{aligned} F &= \sqrt{\left(\frac{2Kq^2}{x^2}\right)^2 + \left(\frac{4Kq^2}{x^2}\right)^2 + 2 \cdot \frac{2Kq^2}{x^2} \cdot \frac{4Kq^2}{x^2} \cos 120^\circ} \\ &= \sqrt{\left(\frac{2Kq^2}{x^2}\right)^2 + \left(\frac{4Kq^2}{x^2}\right)^2 + 2 \cdot \frac{2Kq^2}{x^2} \times \frac{4Kq^2}{x^2} \times \left(-\frac{1}{2}\right)} \\ &= \sqrt{4 \left(\frac{Kq^2}{x^2}\right)^2 + 16 \left(\frac{Kq^2}{x^2}\right)^2 - 8 \left(\frac{Kq^2}{x^2}\right)^2} \\ &= \frac{Kq^2}{x^2} \sqrt{4 + 16 - 8} = \frac{Kq^2}{x^2} \sqrt{12} = 2\sqrt{3} \frac{Kq^2}{x^2} \end{aligned}$$

$$\therefore \vec{F} = 2\sqrt{3} \frac{Kq^2}{x^2}$$

$$(b) U = \frac{K|q_A| \cdot |q_B|}{r_{AB}} + \frac{K|q_A| \cdot |q_C|}{r_{AC}} + \frac{K|q_B| \cdot |q_C|}{r_{BC}}$$

$$\left[ \because \text{for three point charges } U = \frac{k q_1 q_2}{r_{12}} + \frac{k q_1 q_3}{r_{13}} + \frac{k q_2 q_3}{r_{23}} \right]$$

$$\begin{aligned} &= \frac{K|q| \cdot |-4q|}{x} + \frac{K|q| \cdot |2q|}{x} + \frac{K|-4q| \cdot |2q|}{x} \\ &= \frac{4Kq^2}{x} + \frac{2Kq^2}{x} + \frac{8Kq^2}{x} = \frac{14Kq^2}{x} \end{aligned}$$

### LA-II (5 marks)

- (a) An electric dipole of dipole moment  $\vec{p}$  consists of point charges +q and -q separated by a distance 2l apart. Deduce the expression for the electric field  $\vec{E}$  due to the dipole at a distance r from the centre of the dipole on its axial line in terms of the dipole moment  $\vec{p}$ .

Hence, show that in the limit  $r \gg l$ ,

$$\vec{E} = \frac{p}{4\pi\epsilon_0 r^3}$$

(b) Consider a uniform electric field  $\vec{E} = 3 \times 10^3 \hat{i}$  N/C. what is the flux of this field through a square of 10 cm on a side whose plane is parallel to theyzplane?

Answer:

(a) **Electric field at any point P on the axial line**

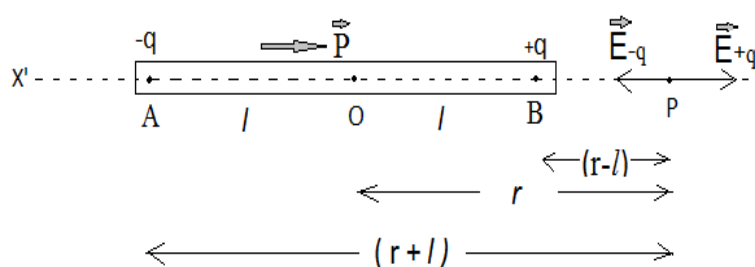

Suppose an electric dipole AB of charges  $\pm q$ , dipole length  $2l$  and dipole moment  $\vec{p}$  is placed in air. We have to calculate electric field at point P on the axial line at distance  $r$  from O. For this, we imagine a unit positive charge at point P.

Now, Magnitude of electric field at point P due to charge  $+q$  will,

$$E_{+q} = \frac{q}{4\pi\epsilon_0 (BP)^2} = \frac{q}{4\pi\epsilon_0 (r-l)^2} \dots\dots (i) \quad [\text{along P to X}]$$

And magnitude of electric field at point P due to charge  $-q$  will,

$$E_{-q} = \frac{q}{4\pi\epsilon_0 (AP)^2} = \frac{q}{4\pi\epsilon_0 (r+l)^2} \dots (ii) \quad [\text{along P to X}']$$

$\therefore$  Magnitude of net electric field at point P due to whole dipole will,

$$\begin{aligned} E &= E_{+q} - E_{-q} = \frac{q}{4\pi\epsilon_0 (r-l)^2} - \frac{q}{4\pi\epsilon_0 (r+l)^2} \\ &= \frac{q}{4\pi\epsilon_0} \left[ \frac{1}{(r-l)^2} - \frac{1}{(r+l)^2} \right] = \frac{q}{4\pi\epsilon_0} \left[ \frac{(r+l)^2 - (r-l)^2}{(r-l)^2 (r+l)^2} \right] \\ &= \frac{q}{4\pi\epsilon_0} \left[ \frac{4rl}{(r^2 - l^2)^2} \right] \quad [\because (a+b)^2 - (a-b)^2 = 4ab] \\ &= \frac{2r(2ql)}{(r^2 - l^2)^2} = \frac{2r \times p}{(r^2 - l^2)^2} \quad [\because p = 2ql] \end{aligned}$$

$$\therefore E = \frac{2pr}{(r^2 - l^2)^2} \dots\dots\dots (iii)$$

If  $r \gg l$  then neglecting  $l^2$ , we get from equation (iii),

$$E = \frac{2pr}{r^4} \quad \text{or} \quad E_A = \frac{2p}{r^3} \dots\dots\dots (iv)$$

In vector form,  $\vec{E}_A = \frac{2\vec{p}}{r^3}$

Its direction is along P to X i.e. along  $\vec{p}$ .

(b) Given,

Electric field intensity  $\vec{E} = 3 \times 10^3 \hat{i}$  N/C or  $E = 3 \times 10^3$  N/C,  
 Area of square A = side<sup>2</sup> =  $10^2 = 100 \text{ cm}^2 = 100 \times 10^{-4} \text{ m}^2 = 10^{-2} \text{ m}^2$ ,  
 Electric flux passing through the plane of square  $\phi = ?$

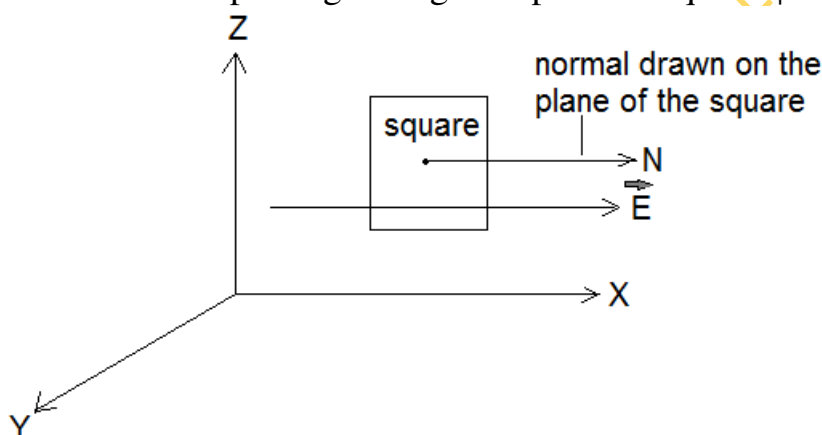

Since, the plane of the square is parallel to the y-z plane and direction of electric field is along X- axis. Therefore, angle between the normal drawn on plane of square and direction of  $\vec{E}$  is  $\theta = 0^\circ$ .

$$\therefore \phi = EA \cos \theta = 3 \times 10^3 \times 10^{-2} \times \cos 0^\circ = 30 \text{ Nm}^2\text{C}^{-1}.$$

2. (a) Explain, using suitable diagrams, the difference in the behavior of a (i) conductor and (ii) dielectric ; in the presence of external electric field.

Define the terms polarization of a dielectric and write its relation with susceptibility.

(b) A thin metallic spherical shell of radius R carries a charge Q on its surface.

A point charge  $\frac{Q}{2}$  is placed at its Centre C and another charge +2Q is placed outside the shell at a distance x from the Centre as shown in the

figure.

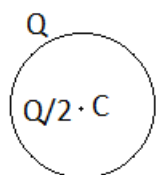

Find (i) The force on the charge at the Centre of shell and at the point A,  
 (ii) the electric flux through the shell.

Answer:

(a)

**Conductor:**

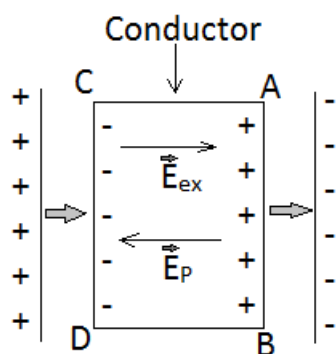

When a conductor ABCD is placed in an external electric field of intensity  $\vec{E}_{ex}$  then free electrons of conductor move from AB side to CD side.

As a result, an opposing electric field  $\vec{E}_p$  induces inside the conductor, which is equal to the external electric field  $\vec{E}_{ex}$ . Therefore, net electric field inside the conductor is zero.

**Dielectric:**

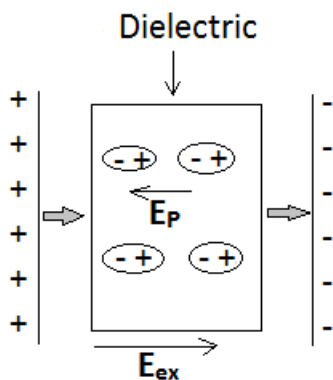

When a dielectric is placed in an external electric field of intensity  $\vec{E}_{ex}$  then some molecules of dielectric are polarized.

As a result, an opposing electric field  $\vec{E}_p$  induces inside the dielectric, which is less than external electric field  $\vec{E}_{ex}$ . Therefore, net electric field inside the conductor is not zero.

**Polarization:**

The dipole moment per unit volume is called polarization( $\vec{P}$ ). For a linear isotropic dielectrics,

$$\vec{P} \propto \vec{E}$$

Or  $\vec{P} = \chi_e \vec{E}$

where  $\chi_e$  is a constant characteristic of the dielectric and is known as the **electric susceptibility** of the dielectric medium.

(b) Charge  $\frac{Q}{2}$  at Centre induces a charge  $-\frac{Q}{2}$  at the inside surface of the shell and  $+\frac{Q}{2}$  at the outside surface. Therefore, net charge on the outer surface will be

$$(Q + \frac{Q}{2}).$$

Now, electric field at point A will be,  $E = \frac{K(Q + \frac{Q}{2})}{x^2}$

(i) Since, the electric field inside a hollow conductor is zero. Therefore, force experienced by the charge  $\frac{Q}{2}$  at the Centre will be zero.

And, the force on charge 2Q at point A will be,

$$F = qE = 2Q \times \frac{K(Q + \frac{Q}{2})}{x^2} = \frac{3Q^2 K}{x^2}$$

(ii) The electric flux through the shell =  $\frac{q_{net}}{\epsilon_0} = \frac{0}{\epsilon_0} = 0$

3. (a) Define electric flux. Is it a scalar or vector quantity ?

A point charge Q is at a distance of d/2 directly above the centre of a square of side “d” as shown in the figure. Use Gauss’s law to obtain the expression for the electric flux through the square.

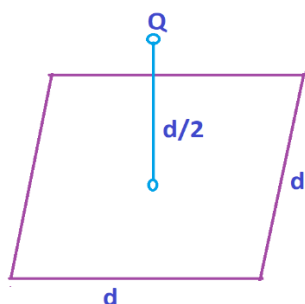

(b) If the point charge is now moved to a distance 'd' from the centre of the square and the side of the square is doubled, explain how the electric flux will be affected.

**Answer:**

(a) The electric field lines passing normally through a surface is called electric flux.

It is a scalar physical quantity.

According to Gauss' law, total electric flux passing through a closed surface is

$$\phi_E = \frac{q_{net}}{\epsilon_0}$$

∴ Electric flux passing through given square,

$$\phi_E = \frac{1}{6} \times \frac{q_{net}}{\epsilon_0} = \frac{Q}{6 \epsilon_0}$$

(b) Since, net charged within closed surface made by cube of side 2d is same as net charge within closed surface by cube of side d.

Therefore, electric flux does not change, when side of square would be doubled and distance of charge would be increased by distance d.

4. (a) Use Gauss's law to derive the expression for the electric field due to a straight uniformly charged infinite line of charge of charged density  $\lambda$  C/m.  
 (b) Draw a graph to show the variation of E with perpendicular distance r from the line of charge.  
 (c) Find the work done in bringing a charge q from perpendicular distance  $r_1$  to  $r_2$  ( $r_2 > r_1$ ).

**Answer:**

(a)

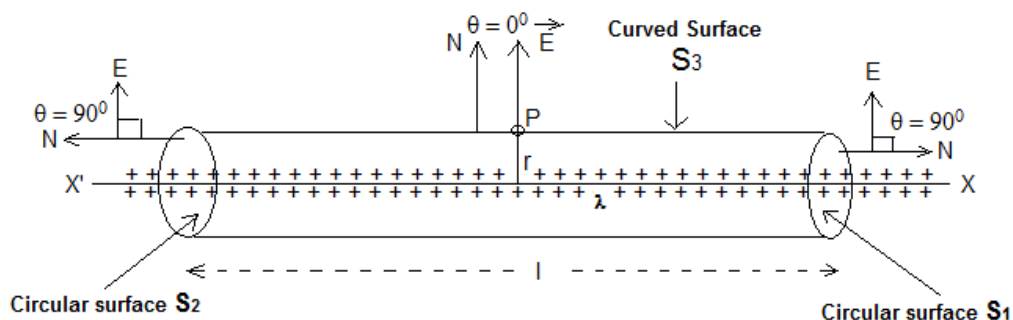

Suppose an infinite long wire is placed in air of linear density of charge  $\lambda$ . We have to calculate electric field intensity at point P at distance  $r$  from wire. For this, we imagine a cylindrical closed surface of length  $l$  and radius  $r$ . The point P is situated on this surface as shown in the figure.

Now, electric flux linked with surface  $S_1$  will,

$$\phi_1 = ES_1 \cos\theta \quad [ \because \phi_E = ES \cos\theta ]$$

$$\text{Or } \phi_1 = ES_1 \cos 90^\circ = 0 \dots\dots(i)$$

[Since, angle between normal drawn on  $S_1$  and direction of E is  $90^\circ$ . ]

Electric field flux linked with surface  $S_2$  will,

$$\phi_2 = ES_2 \cos\theta = ES_2 \cos 90^\circ = 0 \dots\dots(ii)$$

[Since, angle between normal drawn on  $S_2$  and direction of E is  $90^\circ$ . ]

And, electric field flux linked with surface  $S_3$  will,

$$\phi_3 = ES_3 \cos\theta = ES_3 \cos 0^\circ = ES_3$$

[Since, angle between normal drawn on  $S_3$  and direction of E is  $0^\circ$ . ]

$$\text{Or } \phi_3 = E \times 2\pi r l \dots\dots(iii)$$

[ $\because$  Area of curved surface of cylinder =  $2\pi r h = 2\pi r l$  ]

$\therefore$  Total electric flux linked with closed surface will,

$$\phi_E = \phi_1 + \phi_2 + \phi_3 = 0 + 0 + E \times 2\pi r l$$

$$\text{Or } \phi_E = E \times 2\pi r l \dots\dots(iv)$$

According to Gauss's theorem,

$$\phi_E = \frac{q_{net}}{\epsilon_0}$$

Where  $q_{net}$  is net charge inside the closed surface.

$$\text{Or } \phi_E = \frac{\lambda l}{\epsilon_0} \dots\dots(v)$$

[∴ linear density of charge  $\lambda = \frac{q}{l}$  or  $q = \lambda l$  ]

Comparing equations (iv) and (v), we get

$$E \times 2\pi r l = \frac{\lambda l}{\epsilon_0}$$

Or  $E = \frac{\lambda l}{2\pi\epsilon_0 r l}$

Or  $E = \frac{\lambda}{2\pi\epsilon_0 r}$  ..... (vi)

(b)

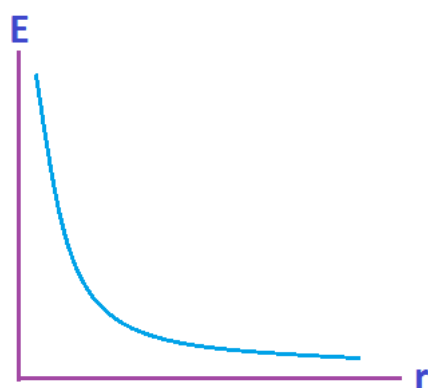

(c)

Required work done ,

$$\begin{aligned} W &= \int_{r_1}^{r_2} F dr = \int_{r_1}^{r_2} qE dr = \int_{r_1}^{r_2} q \frac{\lambda}{2\pi\epsilon_0 r} dr = \frac{\lambda q}{2\pi\epsilon_0} \int_{r_1}^{r_2} \frac{1}{r} dr \\ &= \frac{\lambda q}{2\pi\epsilon_0} \int_{r_1}^{r_2} r^{-1} dr = \frac{\lambda q}{2\pi\epsilon_0} \left[ \frac{r^{-2}}{-2} \right]_{r_1}^{r_2} = \frac{-\lambda q}{4\pi\epsilon_0} [r^{-2}]_{r_1}^{r_2} = \frac{-\lambda q}{4\pi\epsilon_0} \left[ \frac{1}{r^2} \right]_{r_1}^{r_2} \\ &= \frac{-\lambda q}{4\pi\epsilon_0} \left[ \frac{1}{r_2^2} - \frac{1}{r_1^2} \right] \end{aligned}$$

Prepared By

**Er. Servejeet Prasad**

For more topics register on website

<https://www.frequencyphysicsclasses.net> or <https://www.fpconlinecourse.in>